

# CITIZEN

Display Unit for Contact-type Displacement Sensors

## SA-CD1

---

Operation Manual 1st Edition



CITIZEN FINEDEVICE CO., LTD.



## Notes

- Great care has been taken in the preparation of this manual, but there is still a chance that it may contain erroneous explanations or typographical errors.  
If any part of this manual is unclear, or you notice an error or omission, please contact us.
- Read this instruction manual before use and use this unit properly.  
After reading this instruction manual, keep it where you will be able to refer to it again whenever necessary.
- The content of this manual is subject to change without notice.  
The information contained in this manual is subject to periodic changes, details of which are given in the latest edition of the manual.  
CITIZEN FINEDEVICE Co., Ltd. retains the right to change specifications without notice.
- The figures given in this manual may differ from the actual device.
- CITIZEN FINEDEVICE Co., Ltd. reserves all copyrights for this manual.  
No part of this manual may be reproduced, stored in a search system, or transferred, in any form or by any means, electronic or mechanical, including photocopying, without prior permission in writing from CITIZEN FINEDEVICE Co., Ltd.
- Company names and product names mentioned in this manual are trademarks or registered trademarks of the companies concerned.

All Rights Reserved. Copyright © CITIZEN FINEDEVICE Co., Ltd. 2015

First edition issued in May 2015

# Table of Contents

---

<b>1. Instructions for Safe Use</b> .....	<b>1</b>
1-1 Warning .....	1
1-2 Cautions .....	2
1-3 General Precautions.....	2
1-4 Cautions on the Environment of Use.....	3
1-5 Maintenance .....	3
<b>2. Product Overview</b> .....	<b>4</b>
2-1 Outline.....	4
<b>3. Connection and Installation</b> .....	<b>6</b>
3-1 Precautions before Installation.....	6
3-2 Installing the Display Unit's Panel.....	6
3-3 Connection to Detectors.....	7
3-4 Wiring of Power Supply and I/O Cable .....	7
<b>4. Part Names and Functions</b> .....	<b>8</b>
4-1 Control Keys .....	8
4-2 Screen Display.....	9
4-3 Connectors.....	10
<b>5. Mode of Use</b> .....	<b>11</b>
5-1 Overall Flow .....	11
5-2 Overall Flow of Operations .....	12
5-3 Varied Applications.....	16
5-3-1 Master Calibration/Reset function .....	16
5-3-2 Preset Function .....	16
5-3-3 Absolute Value Display and Relative Value Display.....	16
5-3-4 Pass/fail Judgment Function and Rank Determination Function .....	17
5-3-5 Peak Hold Function.....	18
5-3-6 Hold Function .....	19
5-3-7 Averaging Measured Values .....	20
5-3-8 Detector Constant (Lever Ratio Calculation).....	20
5-3-9 Setting the Display Resolution.....	20
5-3-10 Input Monitor .....	20
5-3-11 Display Color of the Screen .....	21
<b>6. Parameter Settings</b> .....	<b>22</b>
6-1 Setting the SET No. Parameters .....	22
6-2 Calling Up the SET No. ....	25
6-3 Setting the Initial Parameters .....	26

---

<b>7. External Input and Output .....</b>	<b>29</b>
7-1 Interface .....	29
7-2 I/O .....	30
7-2-1 Pin Arrangement and Input/Output Circuits .....	30
7-2-2 Cable Connection Method .....	31
7-2-3 Signal Timing .....	32
7-3 BCD .....	33
7-3-1 Pin Arrangement and Input/Output Circuits .....	33
7-3-2 Signal Timing .....	34
7-4 RS-232C .....	35
7-4-1 Pin Arrangement and Input/Output Circuits .....	35
7-4-2 Communication Command Procedure .....	36
7-4-3 Communication Command Format .....	37
7-4-4 Transmission without Using a Communication Command .....	45
<b>8. Troubleshooting .....</b>	<b>46</b>
8-1 Errors .....	46
8-2 In Case of Trouble .....	48
<b>9. Specifications .....</b>	<b>49</b>
9-1 Main Specifications .....	49
9-2 Outline Dimensional Drawings .....	50



# 1. Instructions for Safe Use

This product can be used safely if it is handled properly.  
Improper use may cause a fire or electric shock, resulting in injury or death.  
To prevent such accidents, make sure that you carefully read, fully understand, and then strictly observe the following precautions and the contents of this operation manual.

## 1-1 Warning

**Warnings indicate that failure to observe the instructions may result in death or serious injury.**

### Warning

- Use a power supply within the ratings.  
Use a power supply of 12 to 24 VDC.  
Using any other power voltage may cause a fire or electric shock.
- Keep the power OFF during wiring work.  
Be sure to keep the power OFF during wiring work, such as connecting the power supply or interface. Otherwise an electric shock or failure could occur.
- Do not damage the power cord.  
A damaged power cord may cause a fire or electric shock.  
Observe the following instructions:
  - Do not forcibly bend, twist, or pull the power cord.
  - Do not place any heavy object on the power cord.
  - Keep the power cord away from heaters and chemicals that could melt it.
- Do not open the case.  
Otherwise an electric shock or failure could occur.
- Do not allow any foreign matter, water, or oil to enter the product.  
Any foreign matter, water, or oil entering the product may cause an electric shock, fire, or failure.

Chapter 1  
Instructions for  
Safe Use

Chapter 2  
Product  
Overview

Chapter 3  
Connection and  
Installation

Chapter 4  
Names and  
Functions

Chapter 5  
Mode of Use

Chapter 6  
Parameter  
Settings

Chapter 7  
External Input and  
Output

Chapter 8  
Troubleshooting

Chapter 9  
Specifications

## 1-2 Cautions

**Cautions indicate that failure to observe the instructions could cause injury or cause damage to the device or its surroundings.**

### Cautions

- Do not place any heavy object on, or apply any excessive force to, this device. Doing so may damage the device, which may result in injury.
- Do not subject this device to strong impacts. This is a precision instrument and subjecting it to strong impact may damage it.

## 1-3 General Precautions

- Before using this product, be sure to check that it is working properly in terms of its functions and performance, and make sure that it has not been damaged during transportation.
- Use this product with adequate safeguards to prevent any type of damage, even in of the event of product failure.
- Please note that use of this product outside the standards or usages specified in this operation manual or modification of this product voids any warranty of the product's functions and performance.
- Use in conjunction with another device may impair this product's functions and it may fail to fully demonstrate its performance capability, depending on the conditions of use and the environment. Give due consideration to this before use.
- Never modify, disassemble, or repair with any parts other than those specified in this operation manual. Any damage caused by improper operation, handling, or the environment of use voids this product's warranty.

Chapter 1  
Instructions  
for Safe Use

Chapter 2  
Product  
Overview

Chapter 3  
Connection and  
Installation

Chapter 4  
Names and  
Functions

Chapter 5  
Mode of Use

Chapter 6  
Parameter  
Settings

Chapter 7  
External Input and  
Output

Chapter 8  
Troubleshooting

Chapter 9  
Specifications



---

## 1-4 Cautions on the Environment of Use

Do not use the product in the following locations.

Otherwise an accident or failure could occur.

- Locations where the ambient temperature goes outside the range 0°C to 55°C
- Locations where the ambient humidity goes outside the range 35 to 85% RH
- Locations where there is a lot of water vapor or dust, or where the product could be hit by water, oil, chemicals or welding spatter
- Locations where magnetism, electrostatic charges or vibrations are generated
- Locations subject to direct sunlight
- Locations subject to sudden changes in temperature causing condensation
- Locations where there are corrosive or flammable gases
- Locations where there is a danger of electrical leakage or water leakage
- Locations in the vicinity of open flames, or where heat builds up

## 1-5 Maintenance

- Never disassemble this product.  
Otherwise an accident or failure could occur.
- To remove dirt, wipe it off with a clean, dry cloth.  
Do not use alcohol, thinner, benzene or other volatile solvents. This could cause an accident or failure.
- To remove tough dirt, wipe it off with a cloth moistened with a mild detergent solution.  
Then wipe the part with a cloth with the water completely wrung out, before finally wiping it with a dry cloth.

Chapter 1  
Instructions for  
Safe Use

Chapter 2  
Product  
Overview

Chapter 3  
Connection and  
Installation

Chapter 4  
Names and  
Functions

Chapter 5  
Mode of Use

Chapter 6  
Parameter  
Settings

Chapter 7  
External Input and  
Output

Chapter 8  
Troubleshooting

Chapter 9  
Specifications

## 2. Product Overview

### 2-1 Outline

The SA-CD1 Display Unit can be used to measure size and perform pass/fail judgments when connected to a detector.

#### ■ Display Unit

Model	Characteristics	Pass/fail output	RS-232C communication	BCD output
SA-CD1N	Pass/fail output	○	–	–
SA-CD1N/RS	RS-232C communication	○	○	–
SA-CD1N/BO	BCD output	○	–	○

#### ■ Connectable Detectors (sold separately)

#### Cautions

- Do not connect this product to any product other than those listed below. This could cause an accident or failure.

Model	Characteristics	Measurement range	Resolution	Indication accuracy
SA-S110	Slim type / high-accuracy model	10 mm	0.1 μm	1.0 μm
SA-S510	Slim type / general-purpose model	10 mm	0.5 μm	2.0 μm

Note: The indication accuracy is the value at an ambient temperature of 20°C.



#### Resolution and parameter settings

The resolution varies depending on the connected detector, but can be detected automatically. For this reason there is no need for parameter setting, as there was with previous products.

After replacing the detector with a different one, always turn the power off temporarily and execute “Reset” before using it.

#### ■ Optional (sold separately)

Model	Name	Explanation
SA-CD-SH2M	Detector cable	Straight connector, 2 m
SA-CD-SHL2M	Detector cable	L-shaped connector, 2 m
SA-CD-BO2M	BCD cable	2 m
SA-CD-RS2M	RS-232C cable	With a trigger input cable 2 m

Please ask about lengths other than the above.

Chapter 1  
Instructions for  
Safe Use

Chapter 2  
Product  
Overview

Chapter 3  
Connection and  
Installation

Chapter 4  
Names and  
Functions

Chapter 5  
Mode of Use

Chapter 6  
Parameter  
Settings



Chapter 7  
External Input and  
Output

Chapter 8  
Troubleshooting

Chapter 9  
Specifications

## ■ Composition

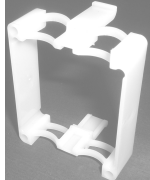
Display Units SA-CD1N, SA-CD1N/RS and SA-CD1N/BO have different interfaces on the rear side.

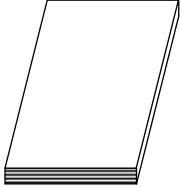
	SA-CD1N	SA-CD1N/RS	SA-CD1N/BO
 <p>Display unit body</p>	○	○	○
 <p>Panel attachment frame (with two M3 × 18 screws)</p>	○	○	○
 <p>I/O connector</p>	○	○	○
 <p>Operation manual</p>	○	○	○
Remarks		The type with a trigger input cable is sold separately. A commercially available interlink cable can be used if trigger input is not required. *1	The BCD connector is not included. The connector with a cable is sold separately.

\*1: The RS-232C cable must not be longer than 2 meters.

Chapter 1  
Instructions for  
Safe Use

Chapter 2  
Product  
Overview

Chapter 3  
Connection and  
Installation

Chapter 4  
Names and  
Functions

Chapter 5  
Mode of Use

Chapter 6  
Parameter  
Settings

Chapter 7  
External Input and  
Output

Chapter 8  
Troubleshooting

Chapter 9  
Specifications

## 3. Connection and Installation

### 3-1 Precautions before Installation

#### ⚠ Cautions

- Do not remove the rubber protective cover around the front panel.  
The protective cover is provided to render the product dustproof, drip-proof and antistatic. Removing the cover will result in failure.
- Do not remove the connector protective cover on the rear side of the unit unless you have connected the connector(s). Removing the cover will result in failure due to static electricity or other causes.

### 3-2 Installing the Display Unit's Panel

#### ■ Panel cut dimensions

The cut dimensions for the display unit attachment panel are shown below.

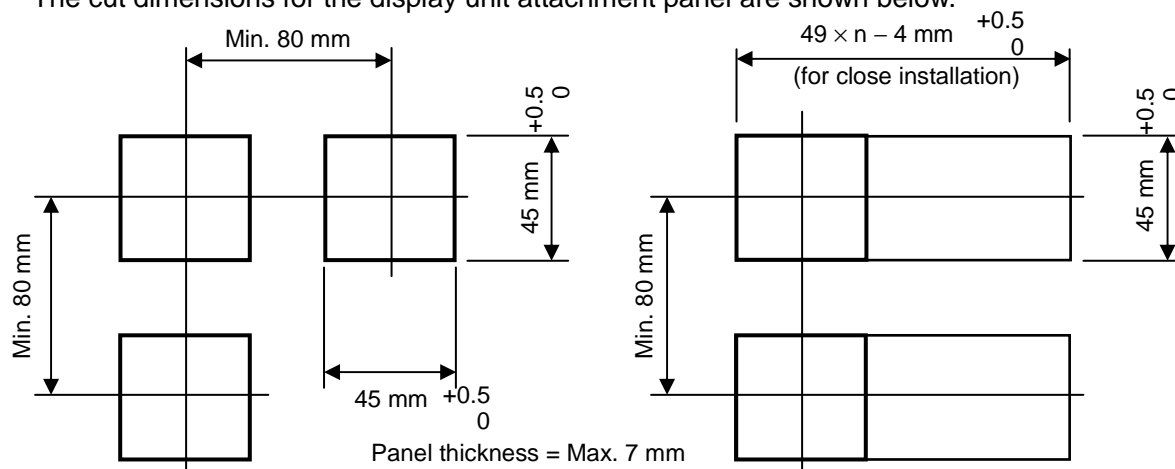

#### ■ Installation to the panel

1. Place the main unit in the panel hole, and insert the attachment frame into the main unit from the rear side. While pulling the main unit to prevent it from moving, push the panel attachment frame into the panel until the edge of the frame is touching the panel surface.
2. While continuing to pull the main unit to prevent it from moving, push the end of the inserter/rejector lever of the panel attachment frame further in until the catches of the panel attachment frame are deeply engaged with the ratchet of the main unit.
3. If the main unit has not been installed stably, evenly tighten the two M3 × 18 tapping screws provided in the open holes located at diagonally opposed positions on the panel attachment frame, and make sure that the main unit is now stable.

## ■ Removal from the panel

1. Loosen the tightened screws until the ends of the screws enter the panel attachment frame.
2. Push the inserter/rejector lever of the panel attachment frame outward with your fingers, disengage the catches on both sides of the panel attachment frame from the main unit, and pull the frame backward.

Chapter 1  
Instructions for  
Safe Use

Chapter 2  
Product  
Overview

Chapter 3  
Connection and  
Installation

Chapter 4  
Names and  
Functions

Chapter 5  
Mode of Use

Chapter 6  
Parameter  
Settings

Chapter 7  
External Input and  
Output

Chapter 8  
Troubleshooting

Chapter 9  
Specifications

## 3-3 Connection to Detectors

### ⚠ Cautions

- Keep the power OFF during wiring work.  
Be sure to switch the power OFF before connecting or disconnecting the detector's cable. Otherwise an electric shock or failure could occur.

Fully insert the connector of the detector into the display unit's detector connector, making sure that the connector shapes fit together.

## 3-4 Wiring of Power Supply and I/O Cable

### ⚠ Warning

- Use a power supply within the ratings.  
Use a power supply of 12 to 24 VDC.  
Using any other power voltage may cause a fire or electric shock.
- Keep the power OFF during wiring work.  
Be sure to keep the power OFF during wiring work. Otherwise an electric shock or failure could occur.  
Make sure that all devices are properly connected before turning the power ON.

There is some instability immediately after the power is turned ON, so the measured values may fluctuate. Wait around ten minutes after turning the power ON before using the display unit.

The connecting positions are shown to the right. Refer to 7-2-2 "Cable Connection Method" (P31) for details on cable connection.

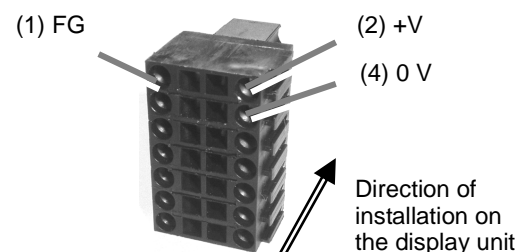

## 4. Part Names and Functions

### 4-1 Control Keys

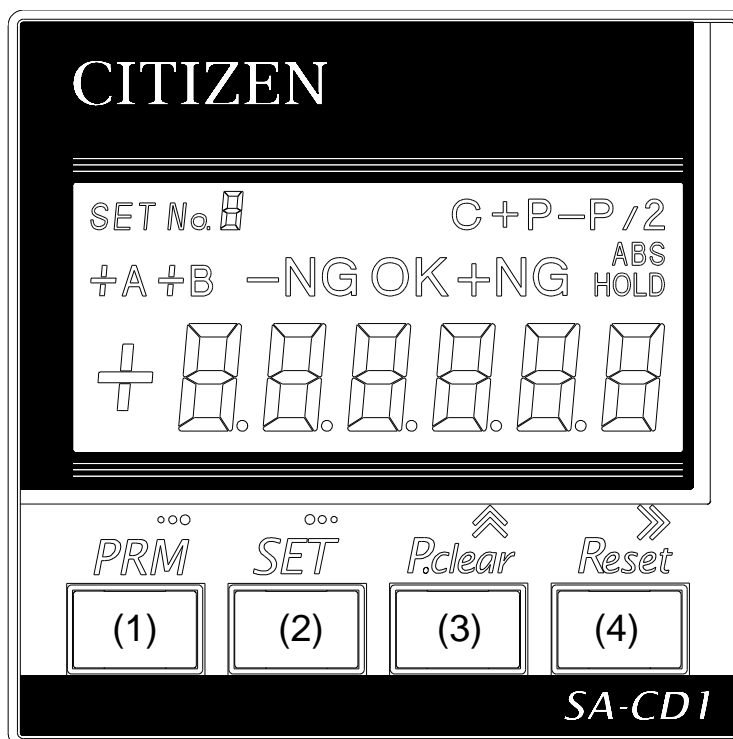

No.	Key	Key name	Description
(1)	PRM	Parameter	Use to set the initial parameters and the SET No. parameters.
(2)	SET	Set	Use to register parameters. Effective only when setting the initial parameters or the SET No. parameters.
(3)	^	Up-arrow	Use to change the numerical value to be entered. Effective only when setting the initial parameters or the SET No. parameters.
	P.clear	Peak clear	Use to clear the peak value. Effective only during measurement.
(4)	>>	Right arrow	Use to shift the digit to input a numerical value for registration of parameters or to input numerical values. Effective only when setting the initial parameters or the SET No. parameters.
	Reset	Reset	Use to set the current measurement value to zero. (or to the PRESET value, if any) Effective only during measurement.

## 4-2 Screen Display

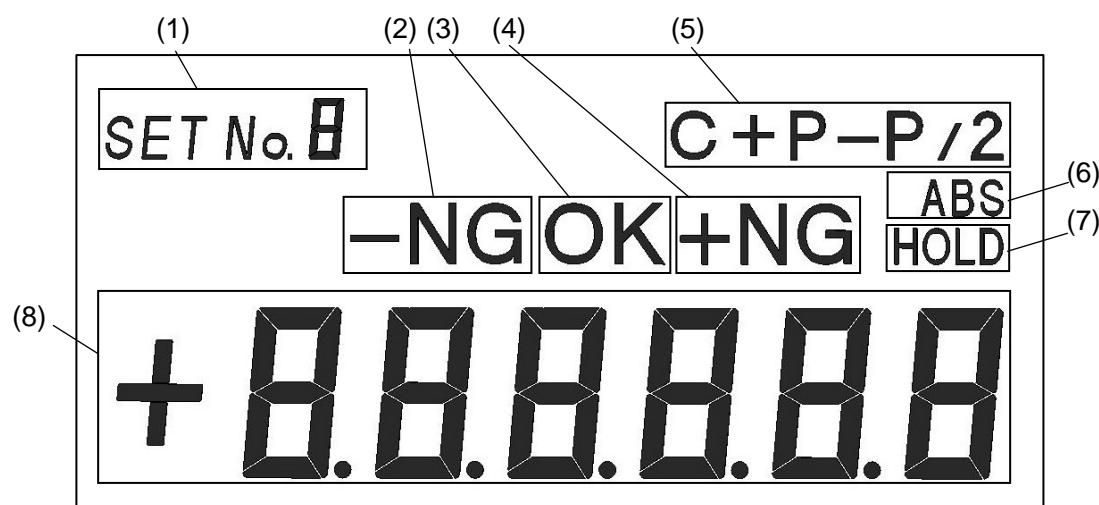

No.	Screen Display	Description	Remarks
(1)	SET No 8	Indicates the selected SET No.	
	8	Indicates the determined rank when the SET No. parameter (No. SP10) is set to r-x. "SET No." is not displayed at this time.	
	-NG	Indicates that the measurement value is lower than the specified "-LIMIT" (lower limit) value.	Displayed only when the SET No. parameter (No. SP10) is set to C-3.
	OK	Indicates that the measurement value is equal to or higher than the specified "-LIMIT" (lower limit) value and is lower than the specified "+LIMIT" (upper limit) value.	
	+NG	Indicates that the measurement value is equal to or higher than the specified "+LIMIT" (upper limit) value.	
(5)	C, +P, -P P-P, P-P/2	Indicates the current measurement mode. C: Current value +P: Maximum value -P: Minimum value P-P: Maximum value - Minimum value P-P/2: (Maximum value - Minimum value) / 2	
(6)	ABS	Indicates that the displacement from the zero point specific to the detector is shown.	
(7)	HOLD	Displayed when hold is executed in response to an external command.	
(8)	±88.8888	Indicates the measurement value.	

Chapter 1  
Instructions for  
Safe Use

Chapter 2  
Product  
Overview

Chapter 3  
Connection and  
Installation

Chapter 4  
Names and  
Functions

Chapter 5  
Mode of Use

Chapter 6  
Parameter  
Settings

Chapter 7  
External Input and  
Output

Chapter 8  
Troubleshooting

Chapter 9  
Specifications

## 4-3 Connectors

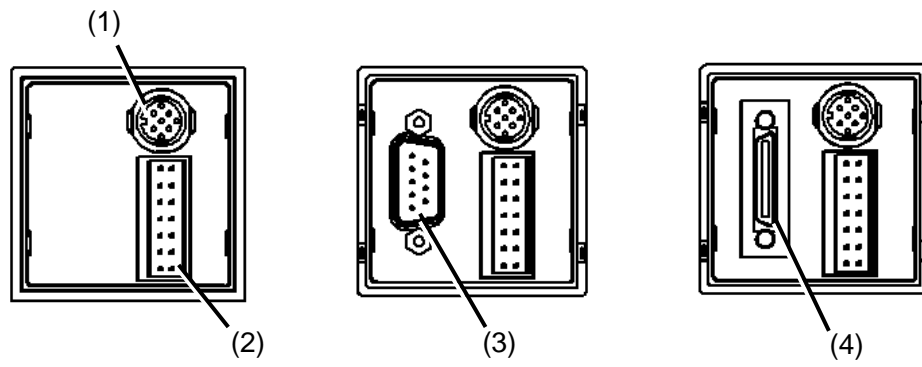

No.	Connector name	Description
(1)	Detector input	Connects to a detector.
(2)	I/O interface	Connects to a power supply and an I/O interface cable.
(3)	RS-232C	Connects to an RS-232C cable.
(4)	BCD	Connects to a BCD cable.

Chapter 1  
Instructions for  
Safe Use

Chapter 2  
Product  
Overview

Chapter 3  
Connection and  
Installation

Chapter 4  
Names and  
Functions

Chapter 5  
Mode of Use

Chapter 6  
Parameter  
Settings

Chapter 7  
External Input and  
Output

Chapter 8  
Troubleshooting

Chapter 9  
Specifications



# 5. Mode of Use

## 5-1 Overall Flow

This unit is provided with a SET No. parameter function.

By registering multiple measurement conditions in the SET No. parameters in advance, measurement conditions can be called up simply by specifying the corresponding SET No. This makes setup changes easy.

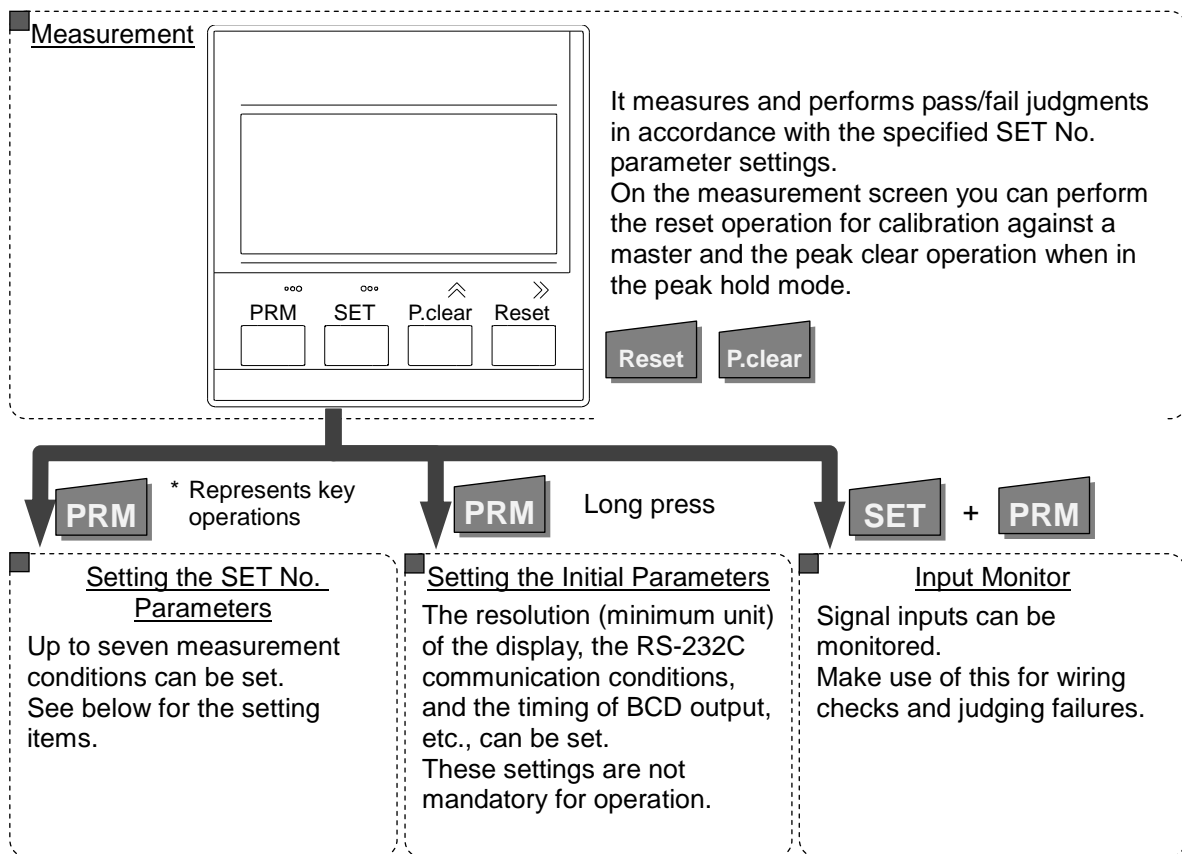

### SET No. parameter

Specify a Set No. by using the following methods.

- By key operation
- By RS-232C command
- By I/O input from the interface connector on the rear of the unit (has priority over other methods)

<SET No. 7> Measurement condition

...

<SET No. 2> Measurement condition

<SET No. 1> Measurement condition

Item	Explanation
Direction setting	Sets the polarity of the spindle thrust direction.
Measurement mode	Sets the current value or peak hold (+P / -P / P-P / P-P/2)
Pass/fail judgment	Sets whether a pass/fail judgment is given or not (sorting into up to 7 ranks possible)
Limit value	Sets the criterion value for pass/fail judgment
Display colors for ranks	Sets the display color for each rank (red, orange, green, all off)
Preset value	Sets the preset value.

- Chapter 1  
Instructions for Safe Use
- Chapter 2  
Product Overview
- Chapter 3  
Connection and Installation
- Chapter 4  
Names and Functions
- Chapter 5  
Mode of Use
- Chapter 6  
Parameter Settings
- Chapter 7  
External Input and Output
- Chapter 8  
Troubleshooting
- Chapter 9  
Specifications

## 5-2 Overall Flow of Operations

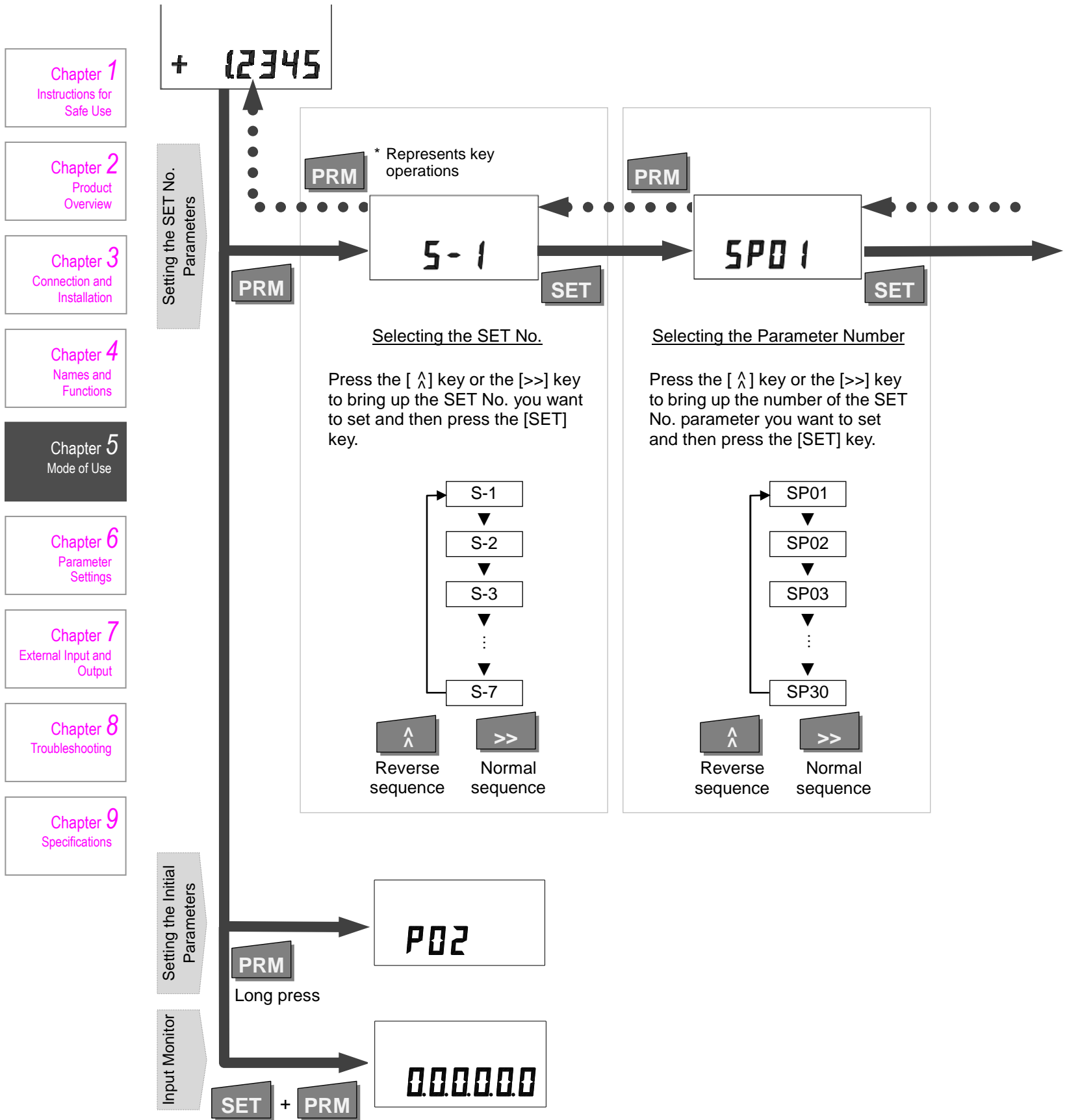

### Setting the SET No. Parameters

For some parameters a selection is input and for others a numerical value is input. The method of input for each is shown in the figure below.

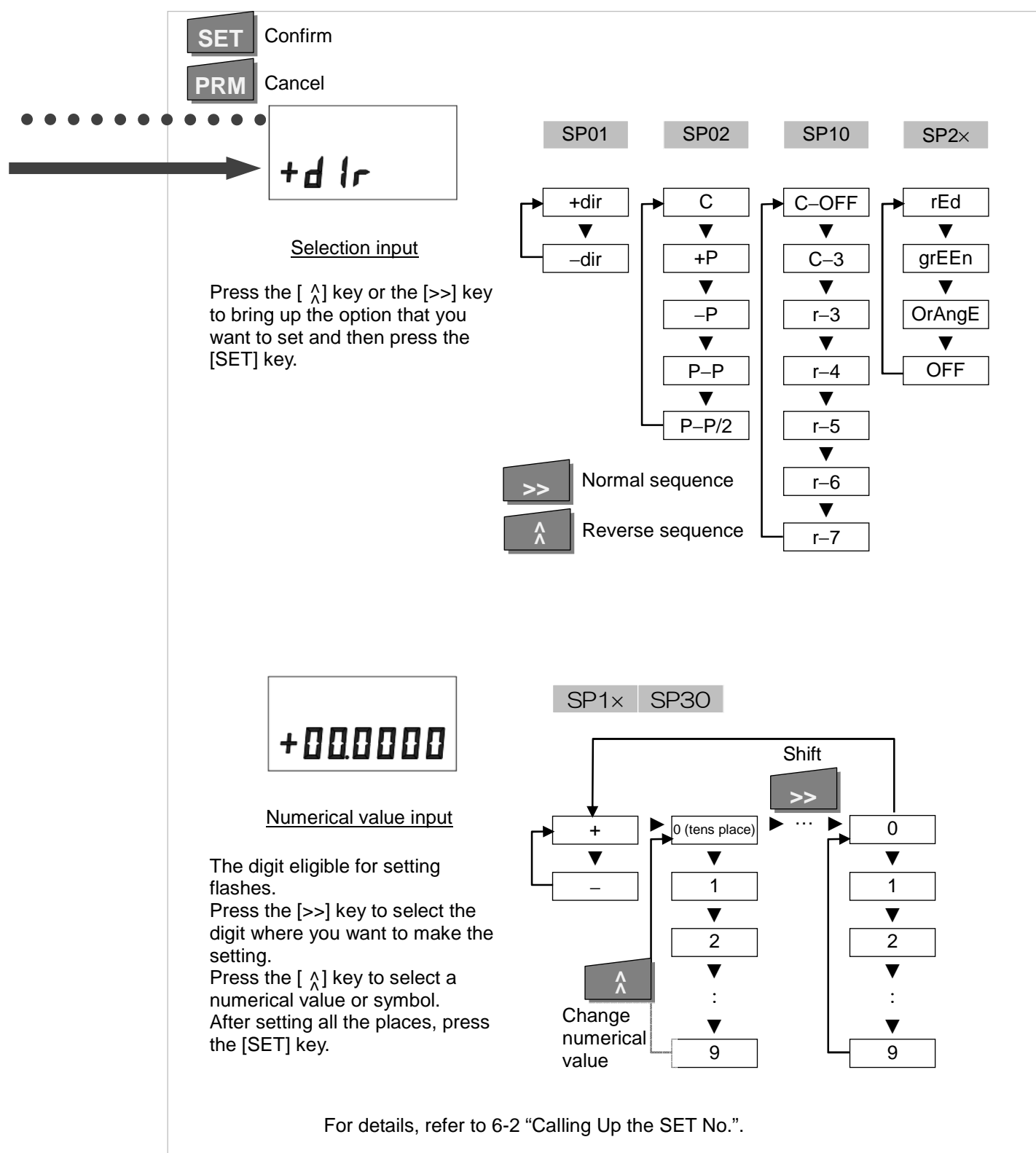

Chapter 1  
Instructions for Safe Use

Chapter 2  
Product Overview

Chapter 3  
Connection and Installation

Chapter 4  
Names and Functions

Chapter 5  
Mode of Use

Chapter 6  
Parameter Settings

Chapter 7  
External Input and Output

Chapter 8  
Troubleshooting

Chapter 9  
Specifications

Chapter 1  
Instructions for  
Safe Use

Chapter 2  
Product  
Overview

Chapter 3  
Connection and  
Installation

Chapter 4  
Names and  
Functions

Chapter 5  
Mode of Use

Chapter 6  
Parameter  
Settings

Chapter 7  
External Input and  
Output

Chapter 8  
Troubleshooting

Chapter 9  
Specifications

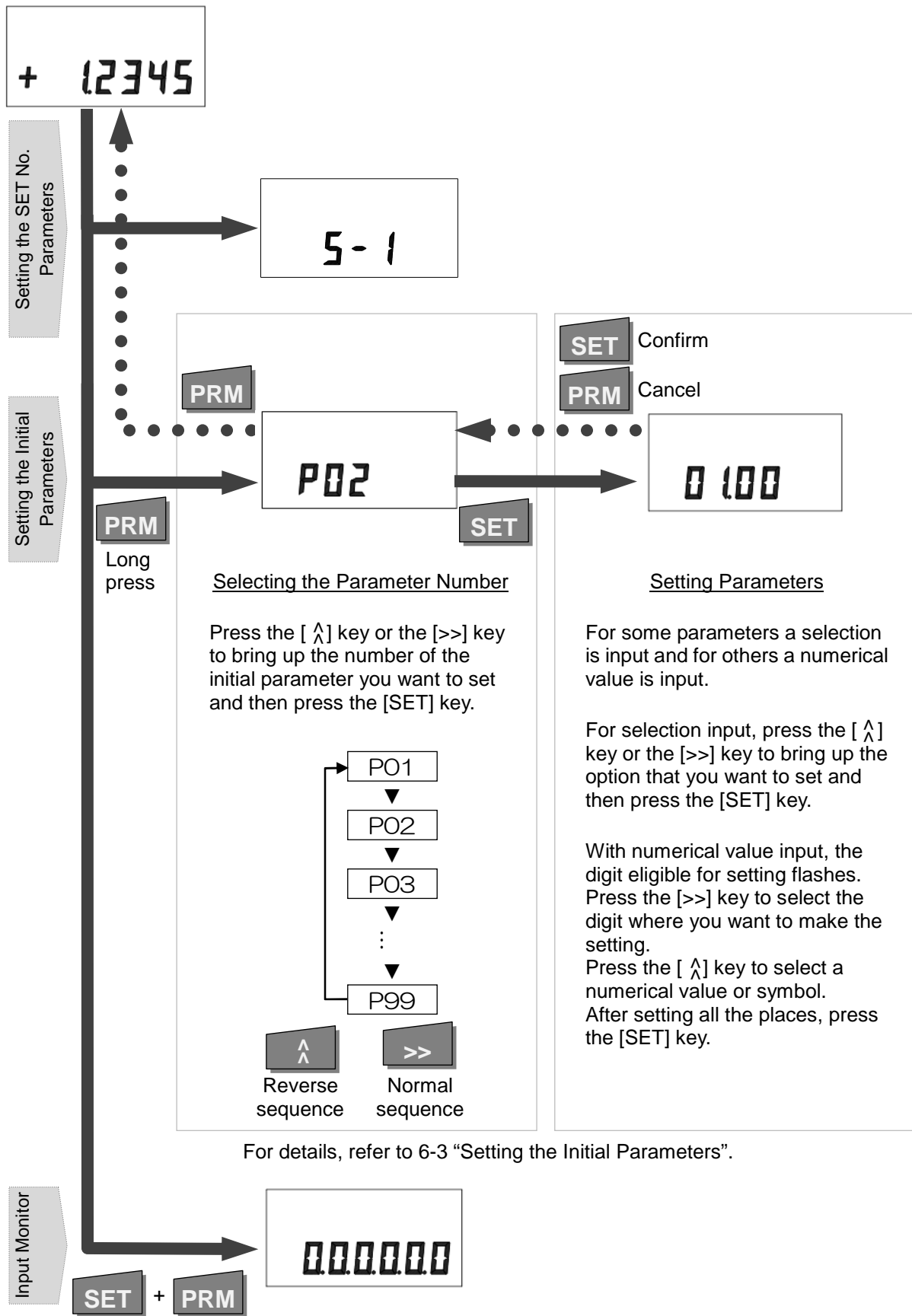

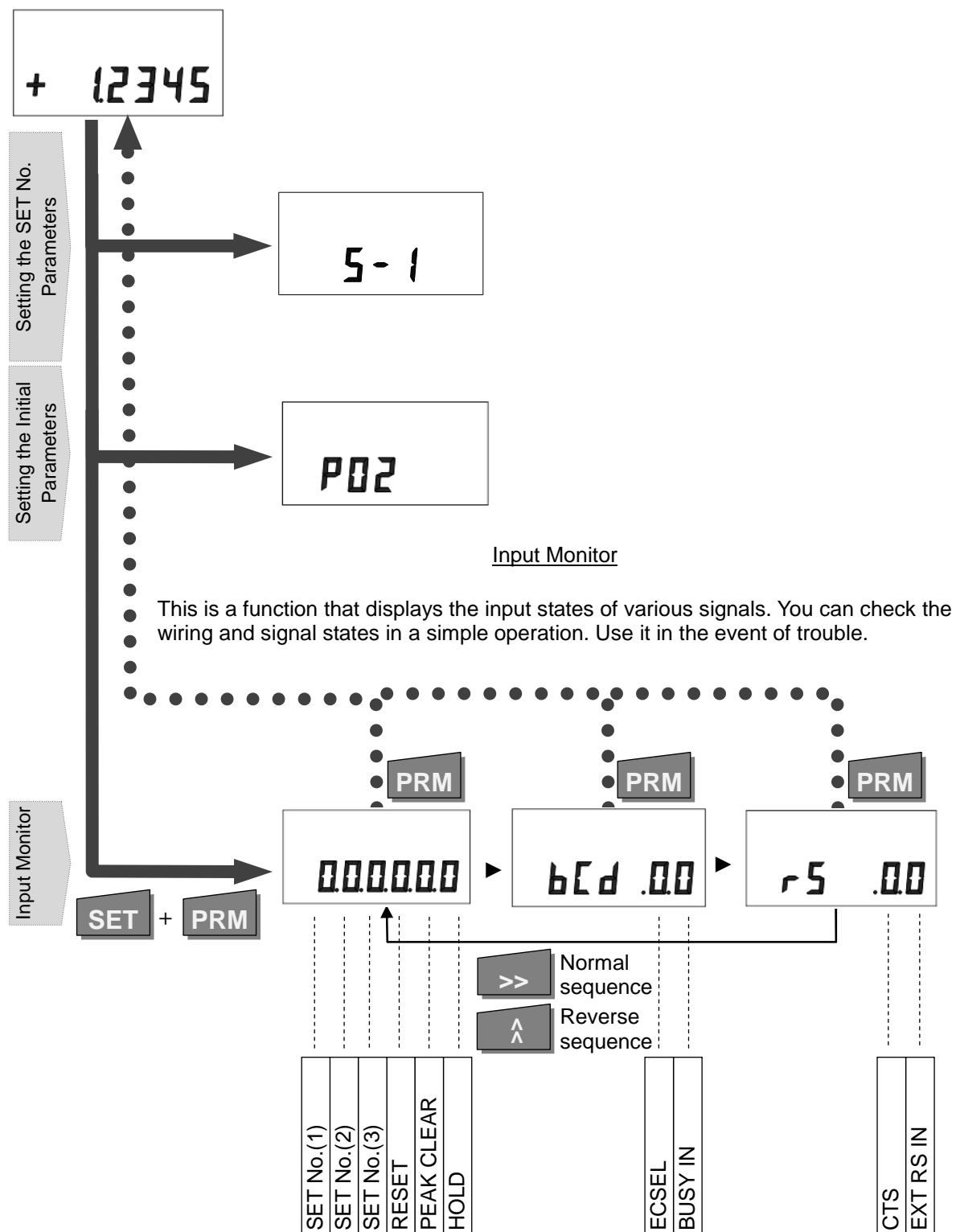

- Chapter 1  
Instructions for Safe Use
- Chapter 2  
Product Overview
- Chapter 3  
Connection and Installation
- Chapter 4  
Names and Functions
- Chapter 5  
Mode of Use
- Chapter 6  
Parameter Settings
- Chapter 7  
External Input and Output
- Chapter 8  
Troubleshooting
- Chapter 9  
Specifications

## 5-3 Varied Applications

### 5-3-1 Master Calibration/Reset function

The reset function serves to set a standard for measurement values using a block gauge, for example. Resetting sets the current value to “0”. If a preset value has been set, the current value becomes the preset value.

Any of the following methods can be used to perform a reset:

- Key operation (Reset)
- Input via I/O (RESET)
- Transmission of a reset command via RS-232C (Zr)

Note: Always reset after replacing the detector with a different one.

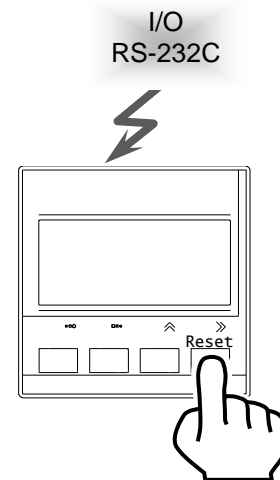

### 5-3-2 Preset Function

This function can add a specified value to the measurement value.

If a preset value has been set, resetting the instrument clears the current value to the preset value.

For details on setting a preset value, refer to 6-1 “Setting the SET No. Parameters”.

For example, when the instrument is reset with a block gauge or other reference, and you wish to indicate that position as 3.5 mm, set a preset value of 3.5 mm.

### 5-3-3 Absolute Value Display and Relative Value Display

Absolute value display is the status where mechanically intrinsic measuring values are displayed, taking the status where the detector’s spindle is projecting to the maximum extent as approximately zero (actually it will be a little on the minus side).

Relative value display is the status where measurement values are displayed by taking the position determined in master calibration using the reset operation described above as the reference.

To set to absolute display, long-press the Reset key. ABS will be displayed on the screen.

To set to relative value display, press the Reset key. The measurement value will be reset.

Chapter 1  
Instructions for  
Safe Use

Chapter 2  
Product  
Overview

Chapter 3  
Connection and  
Installation

Chapter 4  
Names and  
Functions

Chapter 5  
Mode of Use

Chapter 6  
Parameter  
Settings

Chapter 7  
External Input and  
Output

Chapter 8  
Troubleshooting

Chapter 9  
Specifications

### 5-3-4 Pass/fail Judgment Function and Rank Determination Function

These functions determine whether the measurement value is within the specified range of a pass/fail judgment or rank determination, and display or output the result.

For details on how to “enable or disable the pass/fail judgment” or “set limit values”, refer to 6-1 “Setting the SET No. Parameters”.

Each specified limit value is included in the positive (+) direction range as shown below.

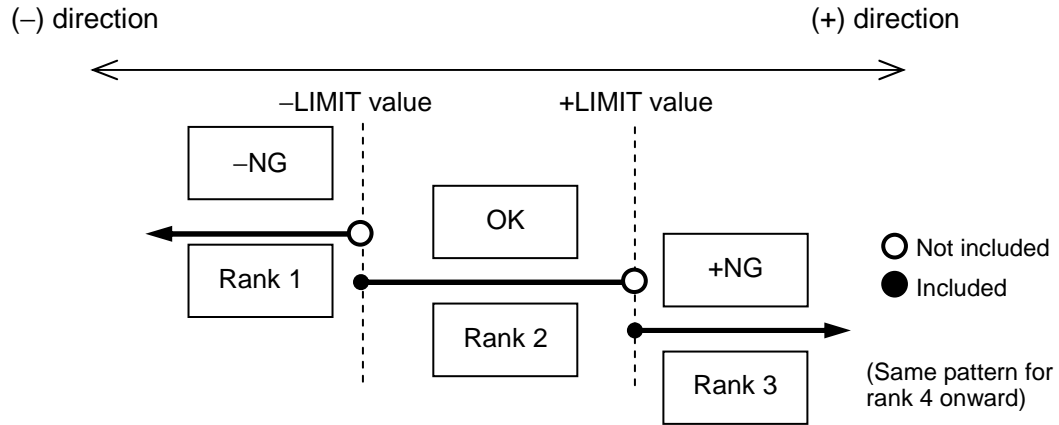

The relationship between judgment and output is listed below:

C-3				r-3 to r-7														
Output	C-3			r-3			r-4			r-5			r-6			r-7		
	-NG	OK	+NG	-NG	OK	+NG	-NG	OK	+NG	-NG	OK	+NG	-NG	OK	+NG	-NG	OK	+NG
-NG	1	0	0	1	0	0	1	0	0	1	0	0	1	0	0	1	0	0
OK	0	1	0	0	1	0	0	1	0	0	1	0	0	1	0	0	1	0
+NG	0	0	1	0	0	1	0	0	1	0	0	1	0	0	1	0	0	1
				/	/	/	0	0	1	0	0	1	0	0	1	0	0	1
				/	/	/	/	/	/	1	0	1	1	0	1	1	0	1
				/	/	/	/	/	/	/	/	/	0	1	1	0	1	1
				/	/	/	/	/	/	/	/	/	/	/	/	1	1	1

Note: Output refers to the open collector output of the NPN transistor.

“0” indicates high impedance and “1” indicates 0 V in the above table.

#### Pass/fail judgment and rank determination

The C-3 setting enables a pass/fail judgment in which there is a one-to-one correspondence between the judgment result and the output port.

The r-3 to r-7 settings enable rank determination in which ranks are determined and expressed in a binary system, as shown in the table above, by using the “-NG,” “OK,” and “+NG” ports.

Chapter 1  
Instructions for  
Safe Use

Chapter 2  
Product  
Overview

Chapter 3  
Connection and  
Installation

Chapter 4  
Names and  
Functions

Chapter 5  
Mode of Use

Chapter 6  
Parameter  
Settings

Chapter 7  
External Input and  
Output

Chapter 8  
Troubleshooting

Chapter 9  
Specifications

### 5-3-5 Peak Hold Function

This function saves measurement value peaks (maximum and minimum values), and displays or outputs “+P” (maximum value), “-P” (minimum value), “P-P” (maximum value – minimum value), and “P-P/2” ((maximum value – minimum value)/2).

For details on the peak hold setting, refer to 6-1 “Setting the SET No. Parameters”.

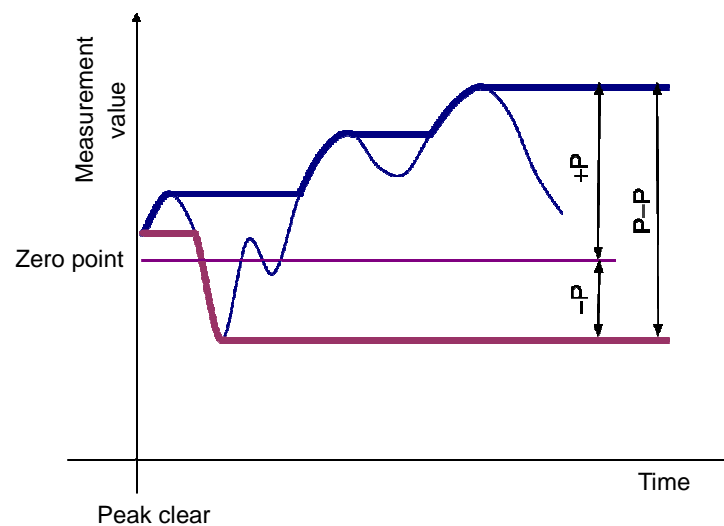

Any of the following methods can be used to clear saved peak values (peak clear):

- Key operation (P. clear)
- Input via I/O (PEAK CLEAR)
- Transmission of the peak clear command via RS-232C (Pr)

Depending on the mode, the reading immediately after a peak clear varies as follows:

- Current values for “+P” and “-P”
- 0 (zero) for “P-P” and “P-P/2”



Chapter 1  
Instructions for  
Safe Use

Chapter 2  
Product  
Overview

Chapter 3  
Connection and  
Installation

Chapter 4  
Names and  
Functions

Chapter 5  
Mode of Use

Chapter 6  
Parameter  
Settings

Chapter 7  
External Input and  
Output

Chapter 8  
Troubleshooting

Chapter 9  
Specifications



### 5-3-6 Hold Function

This function temporarily holds the measurement value.  
This function can be controlled by a hold signal (I/O or RS-232C command) from an external device.

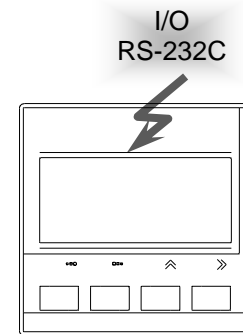

#### Hold signal with reset and peak clear

If a reset or peak clear command is issued while a hold command is active, the command will not be executed immediately but after the hold command has been cleared.

#### Hold signal and peak value updating

Peak values are not updated while a hold command is active. This function can be used to measure peak values just for the arc portion of a workpiece with a D-cut or notch.

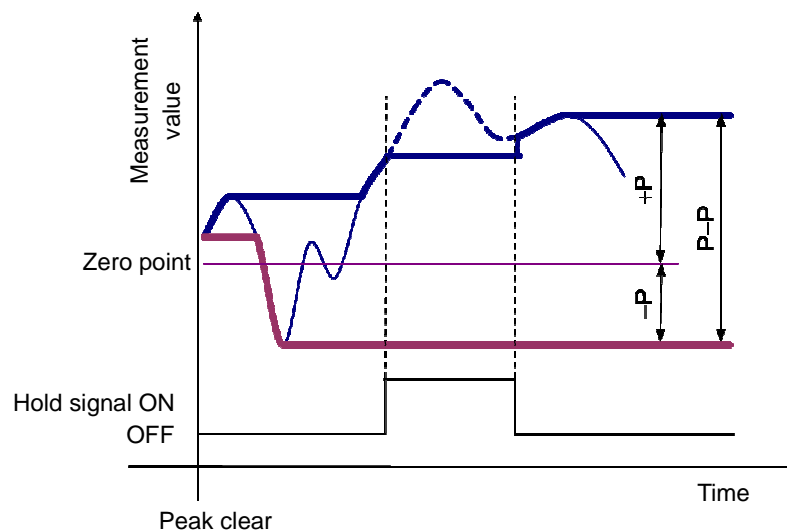

Chapter 1  
Instructions for  
Safe Use

Chapter 2  
Product  
Overview

Chapter 3  
Connection and  
Installation

Chapter 4  
Names and  
Functions

Chapter 5  
Mode of Use

Chapter 6  
Parameter  
Settings

Chapter 7  
External Input and  
Output

Chapter 8  
Troubleshooting

Chapter 9  
Specifications

### 5-3-7 Averaging Measured Values

This function stabilizes the display by obtaining moving averages from internal measured values that are refreshed with a frequency of 1 ms.

Set the count for averaging measured values by setting initial parameter P51.

Note that the response time for signal output varies according to the averaging count.  
(With a count of 10, it is 10 ms.)

### 5-3-8 Detector Constant (Lever Ratio Calculation)

This function multiplies the measurement value by a set value. It enables automatic conversion of the lever ratio in situations such as measurement through a lever.

Set a detector constant by setting initial parameter P02.

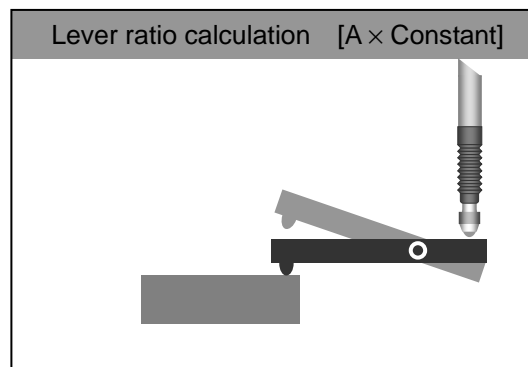

### 5-3-9 Setting the Display Resolution

The display resolution can be specified by setting initial parameter P03.

Data is displayed or output via RS-232C as follows:

Display: Displays only the specified digits and hides any rounded up digits.

<Example> When the resolution is 10  $\mu$ m, 1.2345 (mm) is displayed as 1.23 (mm).

RS-232C: Outputs a value with a fixed number of digits, displaying "0" in place of any rounded up digits.

<Example> When the resolution is 10  $\mu$ m, 1.2345 (mm) is displayed as 1.2300 (mm).

### 5-3-10 Input Monitor

The input monitor function displays the input states of various signals. You can check the wiring and signal states in a simple operation. Use it in the event of trouble.

For details on the display, refer to 5-2 "Overall Flow of Operations".

Chapter 1  
Instructions for  
Safe Use

Chapter 2  
Product  
Overview

Chapter 3  
Connection and  
Installation

Chapter 4  
Names and  
Functions

Chapter 5  
Mode of Use

Chapter 6  
Parameter  
Settings

Chapter 7  
External Input and  
Output

Chapter 8  
Troubleshooting

Chapter 9  
Specifications

---

### 5-3-11 Display Color of the Screen

When performing pass/fail judgments and rank judgments, a setting can be made to switch the display color for each judgment result.

The indicator lamps on the detector also follow this setting.

For details on setting the display colors, refer to 6-1 "Setting the SET No. Parameters".

The display colors can be chosen from among: green, orange, red and off.

Note that the display color when trouble occurs is red and this cannot be changed.

Chapter 1  
Instructions for  
Safe Use

Chapter 2  
Product  
Overview

Chapter 3  
Connection and  
Installation

Chapter 4  
Names and  
Functions

Chapter 5  
Mode of Use

Chapter 6  
Parameter  
Settings

Chapter 7  
External Input and  
Output

Chapter 8  
Troubleshooting

Chapter 9  
Specifications

## 6. Parameter Settings

### 6-1 Setting the SET No. Parameters

Chapter 1  
Instructions for  
Safe Use

Chapter 2  
Product  
Overview

Chapter 3  
Connection and  
Installation

Chapter 4  
Names and  
Functions

Chapter 5  
Mode of Use

Chapter 6  
Parameter  
Settings

Chapter 7  
External Input and  
Output

Chapter 8  
Troubleshooting

Chapter 9  
Specifications

No.	Name	Set values	Remarks
SP01	Direction setting	+dir = Thrust direction is positive (+) -dir = Thrust direction is negative (-)	
SP02	Measurement mode	C = Current value +P = Maximum peak -P = Minimum peak P-P = Maximum peak - Minimum peak P-P/2 = (Maximum peak - Minimum peak)/2	
SP10	Pass/fail judgment (Rank determination)	C-OFF = Disable pass/fail judgment C-3 = Enable pass/fail judgment r-3 = 3-rank determination r-4 = 4-rank determination r-5 = 5-rank determination r-6 = 6-rank determination r-7 = 7-rank determination	
SP11	-LIMIT (LIMIT1)	-99.9999 to +99.9999	
SP12	+LIMIT (LIMIT2)	As above	
SP13	LIMIT3	As above	
SP14	LIMIT4	As above	
SP15	LIMIT5	As above	
SP16	LIMIT6	As above	
SP21	Rank 1 display color	rEd = Lit in red grEE n = Lit in green OrAngE = Lit in orange OFF = Off	
SP22	Rank 2 display color	As above	
SP23	Rank 3 display color	As above	
SP24	Rank 4 display color	As above	
SP25	Rank 5 display color	As above	
SP26	Rank 6 display color	As above	
SP27	Rank 7 display color	As above	
SP30	Preset value	-99.9999 to +99.9999	

---

## ■ Operating procedure

1. On the measurement screen, press the [PRM] key to move to the SET No. parameter setting screen.

2. Using the [ $\wedge$ ] key or the [>>] key, bring up the SET No. you want to set and then press the [SET] key.

This key operation changes the SET No. cyclically as shown below.

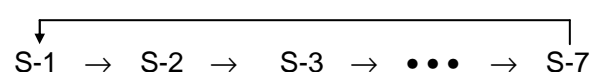

3. Using the [ $\wedge$ ] key or the [>>] key, bring up the number of the parameter you want to set and then press the [SET] key.

This key operation changes the parameter number cyclically as shown below.

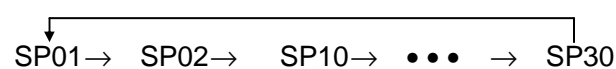

4. Using the [ $\wedge$ ] key or the [>>] key, change the parameter and then press the [SET] key to confirm the setting.

The display returns to the screen for operating procedure 3 (selecting the parameter number). Set parameters sequentially.

5. Press the [PRM] key to exit.

Chapter 1  
Instructions for  
Safe Use

Chapter 2  
Product  
Overview

Chapter 3  
Connection and  
Installation

Chapter 4  
Names and  
Functions

Chapter 5  
Mode of Use

Chapter 6  
Parameter  
Settings

Chapter 7  
External Input and  
Output

Chapter 8  
Troubleshooting

Chapter 9  
Specifications

## ■ Default settings

By default, the SET No. parameters are set as listed below. Use these settings as examples.

No.	Name	SET No.1	SET No.2	SET No.3
SP01	Direction setting	+dir	+dir	+dir
SP02	Measurement mode	C	C	C
SP10	Pass/fail judgment (Rank determination)	C-OFF	C-3	C-OFF
SP11	-LIMIT (LIMIT1)	-	+1.0000	-
SP12	+LIMIT (LIMIT2)	-	+3.0000	-
SP13	LIMIT3	-	-	-
SP14	LIMIT4	-	-	-
SP15	LIMIT5	-	-	-
SP16	LIMIT6	-	-	-
SP21	Rank 1 display color	-	rEd	-
SP22	Rank 2 display color	-	grEEEn	-
SP23	Rank 3 display color	-	rEd	-
SP24	Rank 4 display color	-	-	-
SP25	Rank 5 display color	-	-	-
SP26	Rank 6 display color	-	-	-
SP27	Rank 7 display color	-	-	-
SP30	Preset value	0.0000	0.0000	0.0000

No.	SET No.4	SET No.5	SET No.6	SET No.7
SP01	+dir	+dir	+dir	+dir
SP02	+P	P-P	C	C
SP10	C-OFF	C-OFF	r-7	r-3
SP11	-	-	0.0000	+1.0000
SP12	-	-	+1.0000	+3.0000
SP13	-	-	+2.0000	-
SP14	-	-	+3.0000	-
SP15	-	-	+4.0000	-
SP16	-	-	+5.0000	-
SP21	-	-	rEd	OFF
SP22	-	-	grEEEn	OFF
SP23	-	-	grEEEn	OFF
SP24	-	-	grEEEn	-
SP25	-	-	grEEEn	-
SP26	-	-	grEEEn	-
SP27	-	-	rEd	-
SP30	0.0000	0.0000	0.0000	0.0000

## 6-2 Calling Up the SET No.

### ■ Operating procedure

1. On the measurement screen, press the [PRM] key to move to the SET No. parameter setting screen.  
Using the [ ^ ] key or the [ >> ] key, bring up the SET No. you want to set and then press the [SET] key.  
This key operation changes the SET No. cyclically as shown below.

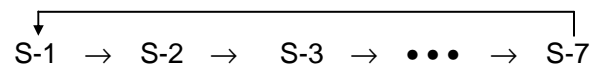

2. Press the [PRM] key to exit.

Chapter 1  
Instructions for  
Safe Use

Chapter 2  
Product  
Overview

Chapter 3  
Connection and  
Installation

Chapter 4  
Names and  
Functions

Chapter 5  
Mode of Use

Chapter 6  
Parameter  
Settings

Chapter 7  
External Input and  
Output

Chapter 8  
Troubleshooting

Chapter 9  
Specifications

## 6-3 Setting the Initial Parameters

Note) x = xxx: default setting

No.	Name	Set values	Remarks
P01	Detector resolution	(Indicates the resolution of the detector)	
P02	Detector constant	00.01 to 99.99 (Default: <u>01.00</u> )	Constant by which the measurement value is multiplied
P03	Display resolution	<u>d-0.1 μ = 0.1 μm</u> d-1 μ = 1 μm d-10 μ = 10 μm	Refer to Section 5-3-9 "Setting the Display Resolution".
P04	Peak clear setting	<u>2-OFF = Disable peak clear at reset</u> 2-On = Enable peak clear at reset	
P06	RS output mode	<u>Sd-1 = Communication command</u> Sd-2 = Internal timer	* Effective when power is turned OFF and back ON
P07	Communication output timer	00.01 to 99.99 sec (Default: <u>01.00 sec</u> )	Effective only when P06 is Sd-2
P08	Error clear signal (I/O)	<u>Er-OFF = Reset (I/O) only</u> Er-On = Reset (I/O) or Error clear	
P30	Communication baud rate	600 (bps) 1200 2400 4800 <u>9600</u> 19200 38400	
P31	Data length	<u>d-8 = 8 bits</u> d-7 = 7 bits	Parameters effective for RS-type only
P32	Stop bit	<u>S-1 = 1 bit</u> S-2 = 2 bits	* Effective when power is turned OFF and back ON
P33	Parity bit	<u>Pn = No parity</u> PE = Even parity PO = Odd parity	
P34	Delimiter	<u>CrLF</u> Cr LF	
P35	XON/XOFF	<u>OFF = Disable</u> On = Enable	
P40	BCD connecting function	<u>OFF = Disable</u> On = Enable	
P41	EOC OFF time	0 to 99 msec. where 0 is approx. 100 μsec. (Default: <u>0</u> )	Parameters effective for BCD-type only

Chapter 1  
Instructions for  
Safe Use

Chapter 2  
Product  
Overview

Chapter 3  
Connection and  
Installation

Chapter 4  
Names and  
Functions

Chapter 5  
Mode of Use

Chapter 6  
Parameter  
Settings

Chapter 7  
External Input and  
Output

Chapter 8  
Troubleshooting

Chapter 9  
Specifications



No.	Name	Set values	Remarks
P42	EOC ON time	1 to 99 msec. (Default: <u>10</u> )	Parameters effective for BCD-type only
P51	Averaging measured values	1 to 256 (Default: <u>50</u> )	
P90	Display unit version	(Indicates the version of the display unit)	
P91	Detector version	(Indicates the version of the detector)	
P98	Parameter initialization	0 to 8 = Disable initialization 9 = Enable initialization (Default: <u>0</u> )	* Initialization is executed when power is turned OFF and back ON
P99	Key lock	<u>L-OFF = OFF</u> L-On = ON	For details on unlocking, see the next page.

Chapter 1  
Instructions for Safe Use

Chapter 2  
Product Overview

Chapter 3  
Connection and Installation

Chapter 4  
Names and Functions

Chapter 5  
Mode of Use

Chapter 6  
Parameter Settings

Chapter 7  
External Input and Output

Chapter 8  
Troubleshooting

Chapter 9  
Specifications

## ■ Operating procedure

1. On the measurement screen, press the [PRM] key for 3 seconds or longer to move to the initial parameter setting screen.
2. Using the [ ^ ] key or the [ >> ] key, bring up the number of the parameter you want to set and then press the [SET] key.  
This key operation changes the parameter number cyclically as shown below.

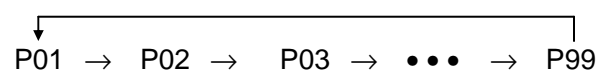

3. Using the [ ^ ] key or the [ >> ] key, change the parameter and then press the [SET] key to confirm the setting.  
The display returns to the screen for operating procedure 2 (selecting the parameter number selection). Set parameters sequentially.
4. Press the [PRM] key to exit.

## ⓘ When a parameter change becomes effective

Parameter changes are confirmed by pressing the [PRM] key to return to the measurement screen.

For parameters indicated in the table as “\* Effective when power is restored”, make sure that you execute this operation before turning the power OFF and back ON.

Chapter 1  
Instructions for  
Safe Use

Chapter 2  
Product  
Overview

Chapter 3  
Connection and  
Installation

Chapter 4  
Names and  
Functions

Chapter 5  
Mode of Use

Chapter 6  
Parameter  
Settings

Chapter 7  
External Input and  
Output

Chapter 8  
Troubleshooting

Chapter 9  
Specifications

### To change the parameters back to the defaults

To change the parameters back to the defaults, set initial parameter P98 to “9” and turn the power OFF and back ON.

Note that this operation initializes all of the initial parameters, SET No. parameters, and all other data in the memory.

### Unlocking the keys

To unlock the keys, simultaneously hold down the [SET], [P-CLEAR], and [RESET] keys for about 3 seconds.

This operation cannot be used to lock the keys. Set the initial parameter to lock the keys.

### P07 communication output timer set value and execution

The time can be set to a minimum of 0.01 seconds. However, if the time required to output a character string is longer than the set time, it cannot be output in the set cycle.

Pay close attention to this, especially when the communication baud rate is low (slow).

### Supplementary explanation of P08 error release signal

The default setting for this product is such that errors cannot be cleared by a reset signal from the I/O connector on the rear side of the unit. This is to prevent a measurement value from being changed by automatic execution of the normal reset process, as well as to prevent secondary accidents where an abnormal state is automatically cleared without an operator check.

Make sure that you fully understand these points when changing the setting.

Note that different RS-232C commands are assigned to zero resetting and error resetting.

Also note that the reset key can be used to perform the error reset process only when an error has occurred.

# 7. External Input and Output

## 7-1 Interface

This product is equipped with various types of interfaces for external input and output. Note that the type of interface varies according to the model. (For details, refer to the following pages.)

When connecting a connector, pay close attention to its direction and connect it properly.

### Interface cable (sold separately)

The following two types of interface cables are available. Select whichever of the cables meets your need.

#### 1) RS-232C + I/O (trigger input) cable

(for exclusive use with SA-CD-RS2M: SA-CD-1/RS)

Note: If you do not need "EXT RS IN" (trigger input), you can use a commercially available interlink cable.

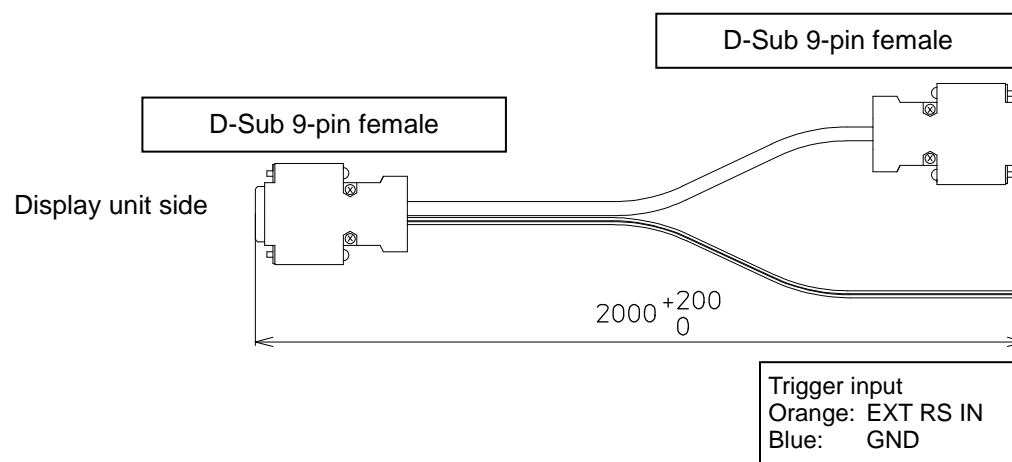

#### 2) BCD cable (for exclusive use with SA-CD-BO2M: SA-CD1/BO)

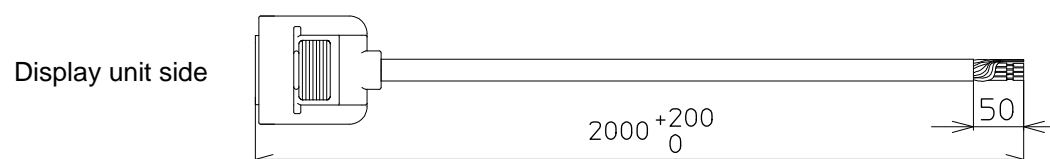

Chapter 1  
Instructions for  
Safe Use

Chapter 2  
Product  
Overview

Chapter 3  
Connection and  
Installation

Chapter 4  
Names and  
Functions

Chapter 5  
Mode of Use

Chapter 6  
Parameter  
Settings

Chapter 7  
External Input and  
Output

Chapter 8  
Troubleshooting

Chapter 9  
Specifications

## 7-2 I/O

### 7-2-1 Pin Arrangement and Input/Output Circuits

The pins are arranged as listed below.

No.	Signal name	I/O	Remarks
1	FG		Frame ground
2	+V		12 to 24 VDC
3	(RSV)	-	
4	0V	-	Power ground
5	-NG/RANK (1)	OUT	-NG judgment output / Rank determination [ $\times 1$ ]
6	OK/RANK (2)	OUT	OK judgment output / Rank determination [ $\times 2$ ]
7	+NG/RANK (3)	OUT	+NG judgment output / Rank determination [ $\times 4$ ]
8	ERROR	OUT	Error output
9	SET No. (1)	IN	SET No. selection (1) (See table below)
10	SET No. (2)	IN	SET No. selection (2) (See table below)
11	SET No. (3)	IN	SET No. selection (3) (See table below)
12	RESET	IN	Reset
13	PEAK CLEAR	IN	Peak clear
14	HOLD	IN	Hold

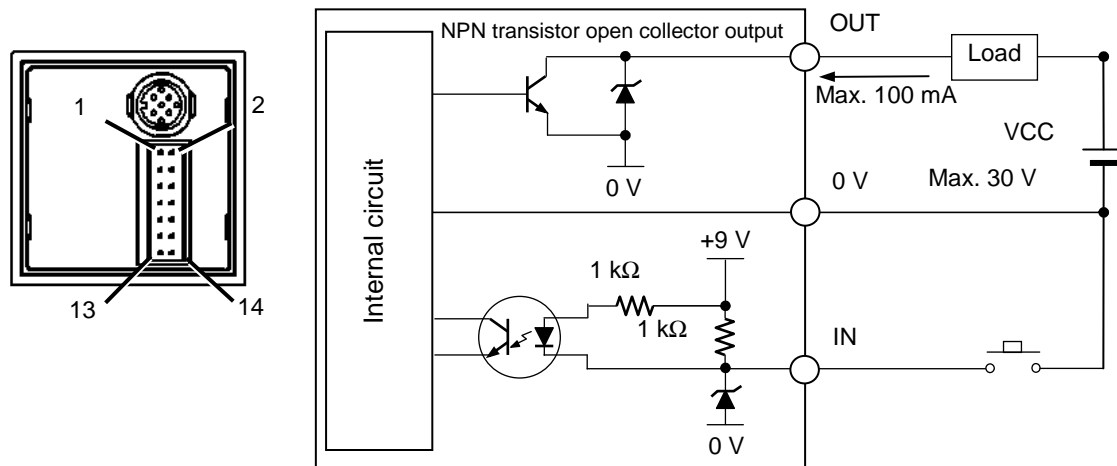

Note: No short circuit protection circuit is provided for outputs.  
Do not connect the power supply directly.

#### SET No. designation

Signal name	Combination of signals to input			
	SET No. (1)	SET No. (2)	SET No. (3)	
SET No. to designate	1	ON	OFF	OFF
	2	OFF	ON	OFF
	3	ON	ON	OFF
	4	OFF	OFF	ON
	5	ON	OFF	ON
	6	OFF	ON	ON
	7	ON	ON	ON

## 7-2-2 Cable Connection Method

The I/O connector (standard accessory) appears as shown below.

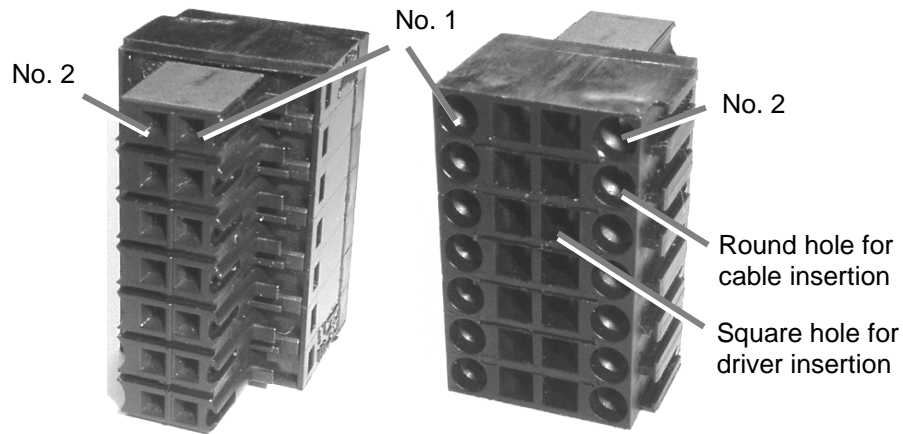

How to connect a cable to the I/O connector

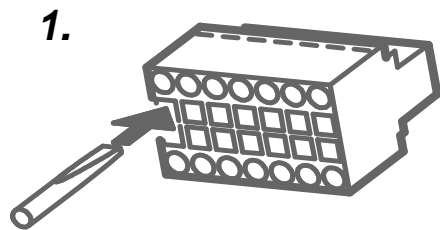

Insert a flat-blade screwdriver meeting the following specification into a square hole for driver insertion as far as it will go. Do not rotate the screwdriver during insertion.

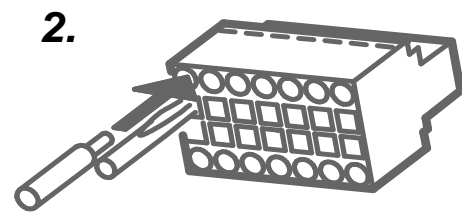

With the screwdriver inserted, insert an electric wire meeting the following specification into a round hole for cable insertion.

- Electric wire specification

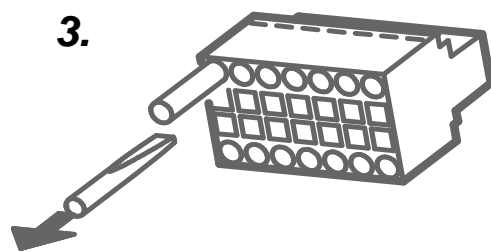
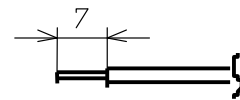

With the cable inserted, pull out the screwdriver. Pull on the electric wire to make sure that it will not come out of the round hole.

- Flat-blade screwdriver specification  
Use a flat-blade screwdriver that has a blade tip shape conforming to DIN5264.

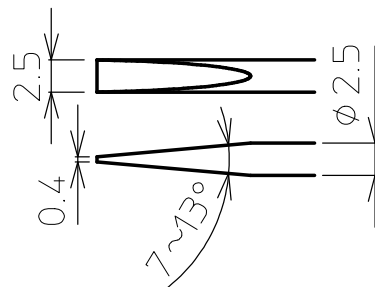

Chapter 1  
Instructions for  
Safe Use

Chapter 2  
Product  
Overview

Chapter 3  
Connection and  
Installation

Chapter 4  
Names and  
Functions

Chapter 5  
Mode of Use

Chapter 6  
Parameter  
Settings

Chapter 7  
External Input and  
Output

Chapter 8  
Troubleshooting

Chapter 9  
Specifications

## 7-2-3 Signal Timing

### Reset and peak clear inputs

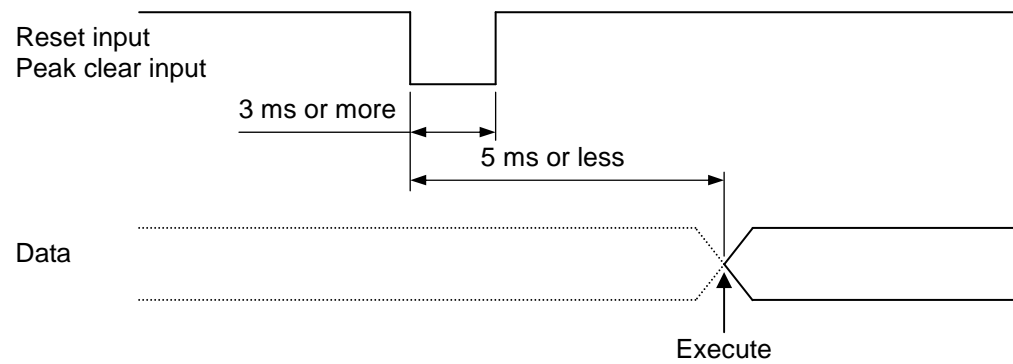

### Hold input

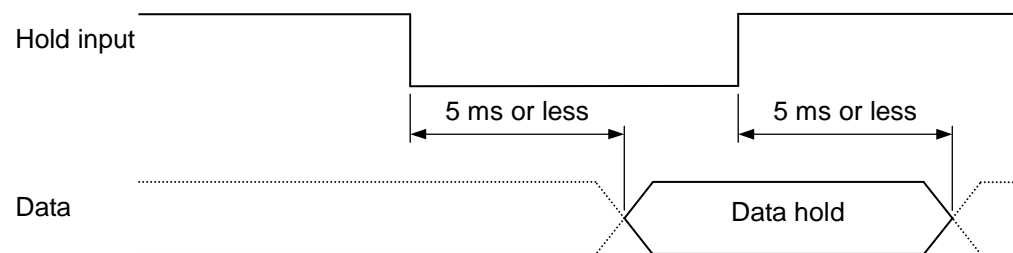

### SET No. (1) (2) (3) input

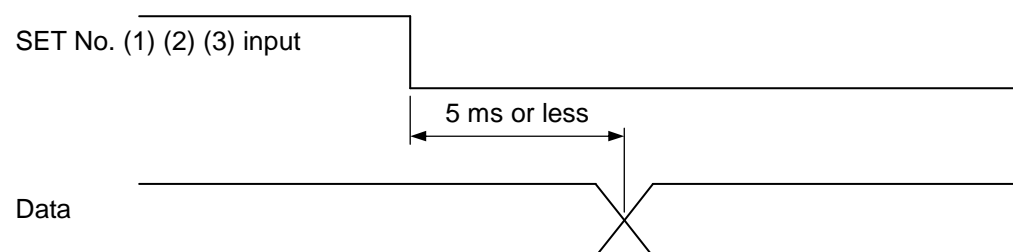

### Pass/fail judgment (Rank)

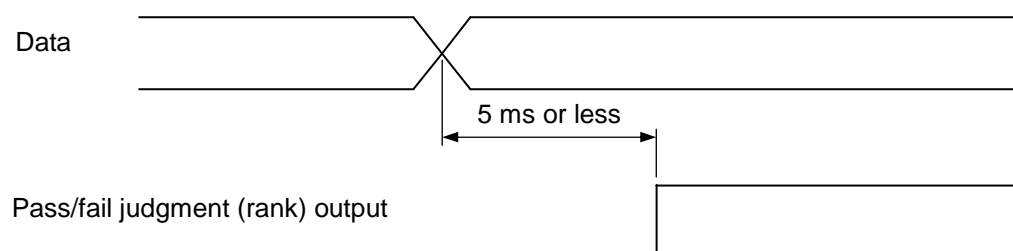

Chapter 1  
Instructions for  
Safe Use

Chapter 2  
Product  
Overview

Chapter 3  
Connection and  
Installation

Chapter 4  
Names and  
Functions

Chapter 5  
Mode of Use

Chapter 6  
Parameter  
Settings

Chapter 7  
External Input and  
Output

Chapter 8  
Troubleshooting

Chapter 9  
Specifications

## 7-3 BCD

### 7-3-1 Pin Arrangement and Input/Output Circuits

The pins are arranged as listed below.

No.	Signal name	I/O	Wire color	Color and number of mark	Remarks
1	DIG0Q1	OUT	Orange	Red 1	First digit of measurement value (i.e. the 0.0001 mm digit)
2	DIG0Q2	OUT	Orange	Black 1	
3	DIG0Q4	OUT	Gray	Red 1	
4	DIG0Q8	OUT	Gray	Black 1	
5	DIG1Q1	OUT	White	Red 1	Second digit of measurement value (i.e. the 0.001 mm digit)
6	DIG1Q2	OUT	White	Black 1	
7	DIG1Q4	OUT	Yellow	Red 1	
8	DIG1Q8	OUT	Yellow	Black 1	
9	DIG2Q1	OUT	Pink	Red 1	Third digit of measurement value (i.e. the 0.01 mm digit)
10	DIG2Q2	OUT	Pink	Black 1	
11	DIG2Q4	OUT	Orange	Red 2	
12	DIG2Q8	OUT	Orange	Black 2	
13	DIG3Q1	OUT	Gray	Red 2	Fourth digit of measurement value (i.e. the 0.1 mm digit)
14	DIG3Q2	OUT	Gray	Black 2	
15	DIG3Q4	OUT	White	Red 2	
16	DIG3Q8	OUT	White	Black 2	
17	DIG4Q1	OUT	Yellow	Red 2	Fifth digit of measurement value (i.e. the 1 mm digit)
18	DIG4Q2	OUT	Yellow	Black 2	
19	DIG4Q4	OUT	Pink	Red 2	
20	DIG4Q8	OUT	Pink	Black 2	
21	DIG5Q1	OUT	Orange	Red 3	Sixth digit of measurement value (i.e. the 10 mm digit)
22	DIG5Q2	OUT	Orange	Black 3	
23	DIG5Q4	OUT	Gray	Red 3	
24	DIG5Q8	OUT	Gray	Black 3	
25	HOLD OUT	OUT	White	Red 3	Holding
26	POL OUT	OUT	White	Black 3	Polarity (Lo: -, Hi: +)
27-28	N.C.				
29	E.O.C OUT	OUT	Yellow	Red 3	Data updating
30-33	N.C.				
34	ECSEL IN	IN	Yellow	Black 3	Display Unit select
35	BUSY IN	IN	Pink	Red 3	Data updating stopped
36	GND		Pink	Black 3	

Note: The wire color and the color and number of the marks indicate the specifications of the optional cables.

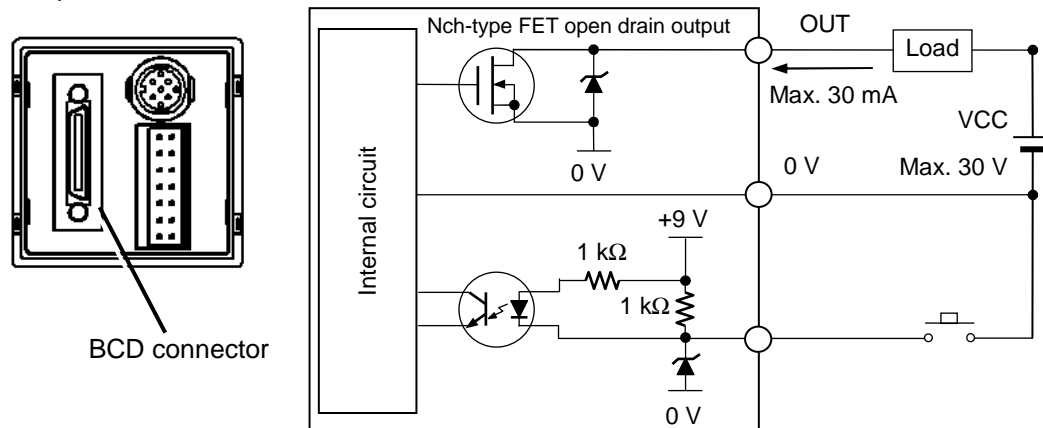

Note: No short circuit protection circuit is provided for outputs. Do not connect the power supply directly.

Chapter 1  
Instructions for  
Safe Use

Chapter 2  
Product  
Overview

Chapter 3  
Connection and  
Installation

Chapter 4  
Names and  
Functions

Chapter 5  
Mode of Use

Chapter 6  
Parameter  
Settings

Chapter 7  
External Input and  
Output

Chapter 8  
Troubleshooting

Chapter 9  
Specifications

## 7-3-2 Signal Timing

### ■ E.O.C. and measurement value

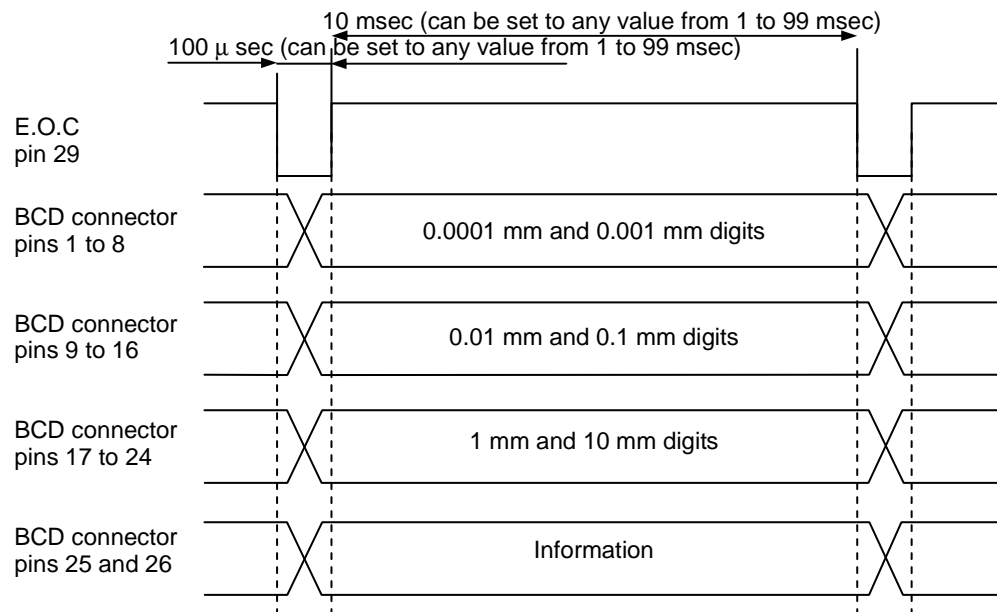

Note: E.O.C. OUT output conditions

- No output during BUSY
- Output during HOLD (No output if the BUSY command is issued simultaneously)
- No output when the BCD connecting function is enabled and display unit select is OFF

### ■ Display unit select

The following operation is executed only when the BCD connecting function (initial parameter P40) is enabled.

When this parameter is disabled, ECSEL is has no meaning.

BCD display unit 1

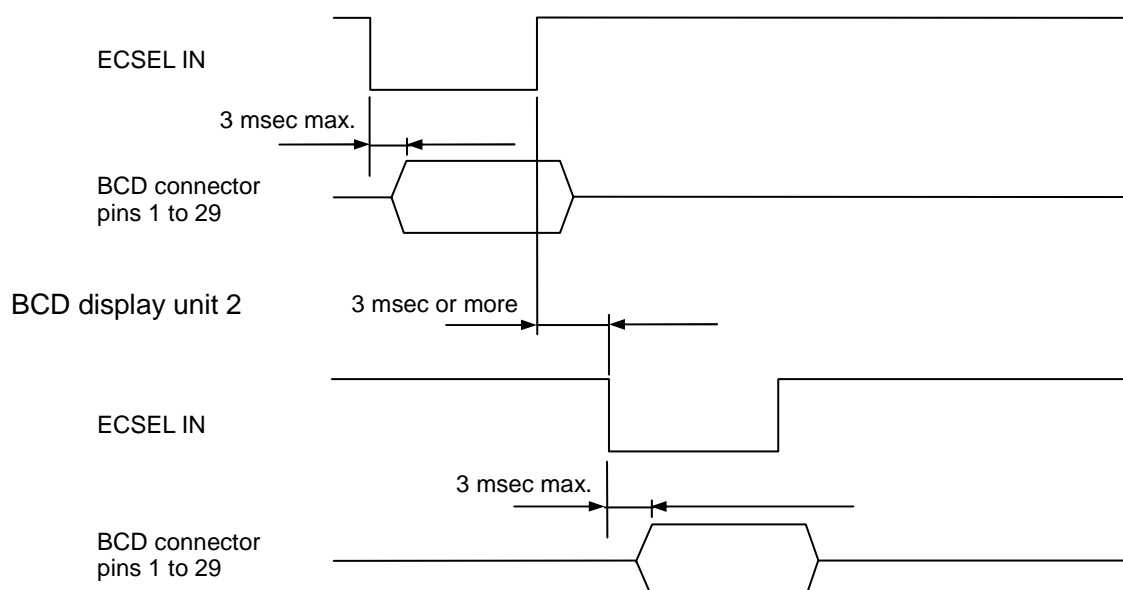



## 7-4 RS-232C

### 7-4-1 Pin Arrangement and Input/Output Circuits

RS-232C pins are arranged as listed below.

Number on the display unit side.	Signal name on the display unit side	I/O	Remarks
2	RxD	IN	Connection to TxD of an external device
3	TxD	OUT	Connection to RxD of an external device
4	DTR	OUT	
5	SG	-	Connection to SG (GND) of an external device
6	DSR	IN	
7	RTS	OUT	Connection to DSR and CTS of an external device
8	CTS	IN	Connection to RTS of an external device
9	EXT RS IN	IN	Trigger input for printer output

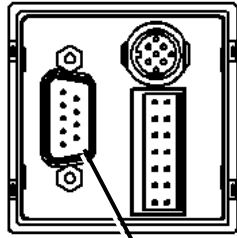

RS-232C connector

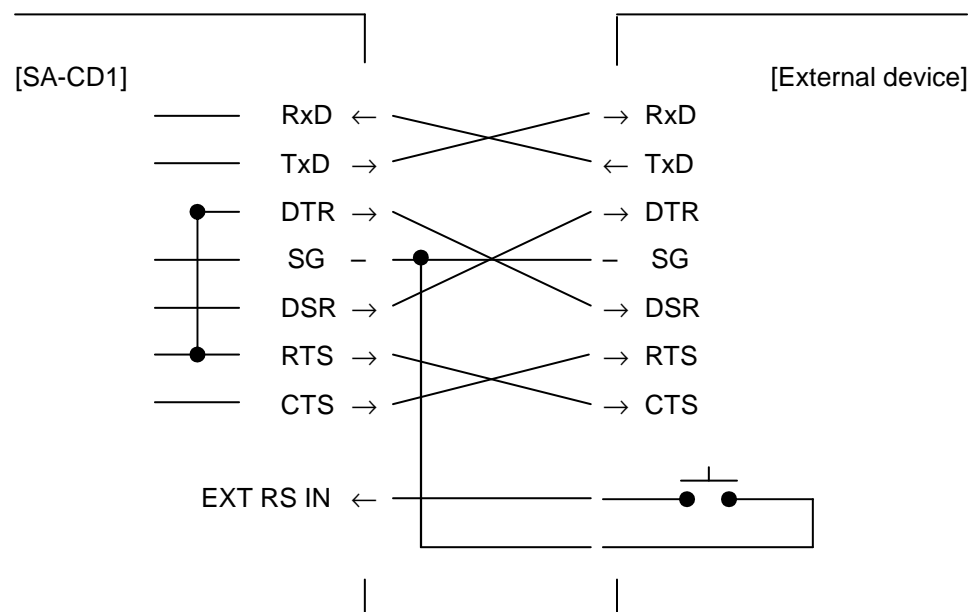

Chapter 1  
Instructions for  
Safe Use

Chapter 2  
Product  
Overview

Chapter 3  
Connection and  
Installation

Chapter 4  
Names and  
Functions

Chapter 5  
Mode of Use

Chapter 6  
Parameter  
Settings

Chapter 7  
External Input and  
Output

Chapter 8  
Troubleshooting

Chapter 9  
Specifications

## 7-4-2 Communication Command Procedure

The communication command procedure and precautions are described below.

- When the initial parameter (communication output mode) is set to communication command support mode, this unit executes communication control using the following command procedure.
- When receiving a command from an external device, such as a PC, the unit sends a response. When a command that requires no reply data is received, the unit sends a receipt acknowledgment.  
If the unit sends no receipt acknowledgment, it indicates that a communication error has occurred.
- All transmitted and received data have a fixed length.  
Note that no data items or digits can be omitted.  
For example, zero (0) must be indicated as "+00.0000", showing zero at each required digit, and with a sign.
- "△" indicates a space (20H) in the formats shown below.
- "C<sub>R</sub>" (0DH) and "L<sub>F</sub>" (0AH) at the ends of lines may, depending on the delimiter specified by the communication setting parameter, be abbreviated to C<sub>R</sub> and L<sub>F</sub> respectively.
- Unless otherwise noted, alphanumeric characters are ASCII characters.  
(When "1" is displayed, it is expressed as 31H in hexadecimal notation.)

### 1) Command receipt acknowledgment (Rs)

Functions	Sends a response to a command that requires no reply data or to a command that could not be received properly.						
Reply format (Display unit → PC)	<table border="1" style="display: inline-table; border-collapse: collapse;"> <tr> <td style="text-align: center;">1</td> <td style="text-align: center;">6</td> </tr> <tr> <td style="text-align: center;">R</td> <td style="text-align: center;">L</td> </tr> <tr> <td style="text-align: center;">s</td> <td style="text-align: center;">F</td> </tr> </table> △ <Receipt acknowledgment code> C <sub>R</sub> L <sub>F</sub>	1	6	R	L	s	F
1	6						
R	L						
s	F						
Data details	Receipt acknowledgment code (1 character) 0 = Command receipt completed 1 = Command format error						

### Setting the parameter P06

To execute the communication command procedure described here, set initial parameter P06 to "Communication command" (Sd-1).

Chapter 1  
Instructions for  
Safe Use

Chapter 2  
Product  
Overview

Chapter 3  
Connection and  
Installation

Chapter 4  
Names and  
Functions

Chapter 5  
Mode of Use

Chapter 6  
Parameter  
Settings

Chapter 7  
External Input and  
Output

Chapter 8  
Troubleshooting

Chapter 9  
Specifications

### 7-4-3 Communication Command Format

#### 1) Initial parameter setting command (Is)

Function	Sets the initial parameters.																										
Transmission format (PC → display unit)	<p>If the initial parameter number is P02 or P07:</p> <table border="1" style="width: 100%; border-collapse: collapse;"> <tr> <td style="width: 10%; text-align: center;">1</td> <td style="width: 10%; text-align: center;">ai</td> <td style="width: 10%; text-align: center;">s</td> <td style="width: 10%; text-align: center;">△</td> <td style="width: 10%; text-align: center;">&lt;CH&gt;</td> <td style="width: 10%; text-align: center;">△</td> <td style="width: 10%; text-align: center;">&lt;Initial parameter number&gt;</td> <td style="width: 10%; text-align: center;">△</td> <td style="width: 10%; text-align: center;">&lt;Parameter data&gt;</td> <td style="width: 10%; text-align: center;">10</td> <td style="width: 10%; text-align: center;">C<sub>R</sub></td> <td style="width: 10%; text-align: center;">L<sub>F</sub></td> <td style="width: 10%; text-align: center;">16</td> </tr> </table> <p>If the initial parameter number is other than P02 and P07:</p> <table border="1" style="width: 100%; border-collapse: collapse;"> <tr> <td style="width: 10%; text-align: center;">1</td> <td style="width: 10%; text-align: center;">ai</td> <td style="width: 10%; text-align: center;">s</td> <td style="width: 10%; text-align: center;">△</td> <td style="width: 10%; text-align: center;">&lt;CH&gt;</td> <td style="width: 10%; text-align: center;">△</td> <td style="width: 10%; text-align: center;">&lt;Initial parameter number&gt;</td> <td style="width: 10%; text-align: center;">△</td> <td style="width: 10%; text-align: center;">&lt;Parameter data&gt;</td> <td style="width: 10%; text-align: center;">10</td> <td style="width: 10%; text-align: center;">C<sub>R</sub></td> <td style="width: 10%; text-align: center;">L<sub>F</sub></td> <td style="width: 10%; text-align: center;">12</td> </tr> </table>	1	ai	s	△	<CH>	△	<Initial parameter number>	△	<Parameter data>	10	C <sub>R</sub>	L <sub>F</sub>	16	1	ai	s	△	<CH>	△	<Initial parameter number>	△	<Parameter data>	10	C <sub>R</sub>	L <sub>F</sub>	12
1	ai	s	△	<CH>	△	<Initial parameter number>	△	<Parameter data>	10	C <sub>R</sub>	L <sub>F</sub>	16															
1	ai	s	△	<CH>	△	<Initial parameter number>	△	<Parameter data>	10	C <sub>R</sub>	L <sub>F</sub>	12															
Reply format (Display unit → PC)	<table border="1" style="width: 100%; border-collapse: collapse;"> <tr> <td style="width: 10%; text-align: center;">1</td> <td style="width: 10%; text-align: center;">R</td> <td style="width: 10%; text-align: center;">s</td> <td style="width: 10%; text-align: center;">△</td> <td style="width: 10%; text-align: center;">&lt;Receipt acknowledgment code&gt;</td> <td style="width: 10%; text-align: center;">C<sub>R</sub></td> <td style="width: 10%; text-align: center;">L<sub>F</sub></td> <td style="width: 10%; text-align: center;">6</td> </tr> </table>	1	R	s	△	<Receipt acknowledgment code>	C <sub>R</sub>	L <sub>F</sub>	6																		
1	R	s	△	<Receipt acknowledgment code>	C <sub>R</sub>	L <sub>F</sub>	6																				
Data details	<p>CH: 01 (fixed)</p> <p>Initial parameter number: 01 to 99 (refer to parameter)</p> <p>Parameter data P02: 00.01 to 99.99</p> <p>P03: 0 = 0.1, 1 = 1, 2 = 10 (μm)</p> <p>P04: 0 = 2-OFF, 1 = 2-ON</p> <p>P06: 0 = Communication command, 1 = Internal timer</p> <p>P07: 00.01 to 99.99 (sec)</p> <p>P08: 0 = Er-OFF, 1 = Er-ON</p> <p>P51: 001 to 256</p> <p>P98: 0 to 9 (9 for parameter initialization)</p> <p>P99: 0 = Key lock OFF, 1 = ON</p>																										

Chapter 1  
Instructions for  
Safe Use

Chapter 2  
Product  
Overview

Chapter 3  
Connection and  
Installation

Chapter 4  
Names and  
Functions

Chapter 5  
Mode of Use

Chapter 6  
Parameter  
Settings

Chapter 7  
External Input and  
Output

Chapter 8  
Troubleshooting

Chapter 9  
Specifications

Chapter 1  
Instructions for  
Safe Use

Chapter 2  
Product  
Overview

Chapter 3  
Connection and  
Installation

Chapter 4  
Names and  
Functions

Chapter 5  
Mode of Use

Chapter 6  
Parameter  
Settings

Chapter 7  
External Input and  
Output

Chapter 8  
Troubleshooting

Chapter 9  
Specifications

2) Initial parameter request command (Ir)

Function	Requests the initial parameters.																														
Transmission format (PC → display unit)	<table border="1"> <tr> <td>1</td> <td>ai</td> <td>r</td> <td>Δ</td> <td>&lt;CH&gt;</td> <td>Δ</td> <td>&lt;Initial parameter number&gt;</td> <td>10</td> <td>C</td> <td>R</td> <td>L</td> <td>F</td> </tr> </table>	1	ai	r	Δ	<CH>	Δ	<Initial parameter number>	10	C	R	L	F																		
1	ai	r	Δ	<CH>	Δ	<Initial parameter number>	10	C	R	L	F																				
Reply format (Display unit → PC)	<p>If the initial parameter number is P02 or P07:</p> <table border="1"> <tr> <td>1</td> <td>ai</td> <td>r</td> <td>Δ</td> <td>&lt;CH&gt;</td> <td>Δ</td> <td>&lt;Initial parameter number&gt;</td> <td>Δ</td> <td>&lt;Parameter data&gt;</td> <td>10</td> <td>C</td> <td>R</td> <td>L</td> <td>F</td> <td>16</td> </tr> </table> <p>If the initial parameter number is other than P02 and P07:</p> <table border="1"> <tr> <td>1</td> <td>ai</td> <td>r</td> <td>Δ</td> <td>&lt;CH&gt;</td> <td>Δ</td> <td>&lt;Initial parameter number&gt;</td> <td>Δ</td> <td>&lt;Parameter data&gt;</td> <td>10</td> <td>C</td> <td>R</td> <td>L</td> <td>F</td> <td>12</td> </tr> </table>	1	ai	r	Δ	<CH>	Δ	<Initial parameter number>	Δ	<Parameter data>	10	C	R	L	F	16	1	ai	r	Δ	<CH>	Δ	<Initial parameter number>	Δ	<Parameter data>	10	C	R	L	F	12
1	ai	r	Δ	<CH>	Δ	<Initial parameter number>	Δ	<Parameter data>	10	C	R	L	F	16																	
1	ai	r	Δ	<CH>	Δ	<Initial parameter number>	Δ	<Parameter data>	10	C	R	L	F	12																	
Data details	<p>CH: 01 (fixed)</p> <p>Initial parameter number: 01 to 99 (refer to parameter)</p> <p>Parameter data P02: 00.01 to 99.99</p> <p>P03: 0 = 0.1, 1 = 1, 2 = 10 (μm)</p> <p>P04: 0 = 2-OFF, 1 = 2-ON</p> <p>P06: 0 = Communication command, 1 = Internal timer</p> <p>P07: 00.01 to 99.99 (sec)</p> <p>P08: 0 = Er-OFF, 1 = Er-ON</p> <p>P51: 001 to 256</p> <p>P98: 0 to 9 (9 for parameter initialization)</p> <p>P99: 0 = Key lock OFF, 1 = ON</p>																														



4) SET No. parameter request command (Sr)

Function	Requests the SET No. parameters.																																																																																																																				
Transmission format (PC → display unit)	<table border="1"> <tr> <td>1</td> <td>S</td> <td>r</td> <td>△</td> <td>&lt;CH&gt;</td> <td>△</td> <td>&lt;SET No.&gt;</td> <td>C<sub>R</sub></td> <td>L<sub>F</sub></td> <td>9</td> </tr> </table>	1	S	r	△	<CH>	△	<SET No.>	C <sub>R</sub>	L <sub>F</sub>	9																																																																																																										
1	S	r	△	<CH>	△	<SET No.>	C <sub>R</sub>	L <sub>F</sub>	9																																																																																																												
Reply format (Display unit → PC)	<table border="1"> <tr> <td>1</td> <td>S</td> <td>r</td> <td>△</td> <td>&lt;CH&gt;</td> <td>△</td> <td>&lt;SET No.&gt;</td> <td>△</td> <td>&lt;Direction setting&gt;</td> <td>10</td> <td>&lt;Measurement mode&gt;</td> <td>△</td> <td>&lt;Pass/fail judgment&gt;</td> <td>△</td> </tr> <tr> <td colspan="13"> <table border="1"> <tr> <td colspan="6">&lt;-LIMIT&gt;</td> <td>20</td> <td>△</td> <td colspan="3">&lt;+LIMIT&gt;</td> <td>30</td> <td>△</td> </tr> <tr> <td colspan="6">&lt;LIMIT3&gt;</td> <td>40</td> <td>△</td> <td colspan="3">&lt;LIMIT4&gt;</td> <td>50</td> <td>△</td> </tr> <tr> <td colspan="6">&lt;LIMIT5&gt;</td> <td>60</td> <td>△</td> <td colspan="3">&lt;LIMIT6&gt;</td> <td>70</td> <td>△</td> </tr> <tr> <td colspan="3">&lt;Rank 1 display color&gt;</td> <td>70</td> <td>△</td> <td colspan="3">&lt;Rank 2 display color&gt;</td> <td>△</td> <td colspan="3">&lt;Rank 3 display color&gt;</td> <td>△</td> <td colspan="3">&lt;Rank 4 display color&gt;</td> <td>△</td> </tr> <tr> <td colspan="3">&lt;Rank 5 display color&gt;</td> <td>80</td> <td>△</td> <td colspan="3">&lt;Rank 6 display color&gt;</td> <td>△</td> <td colspan="3">&lt;Rank 7 display color&gt;</td> <td>△</td> <td colspan="3"></td> </tr> <tr> <td colspan="11">&lt;Preset value&gt;</td> <td>90</td> <td>C<sub>R</sub></td> <td>L<sub>F</sub></td> <td>92</td> </tr> </table> </td> </tr> <tr> <td>Data details</td> <td> <p>CH: 01 (fixed)</p> <p>SET No.: 1 to 7</p> <p>Direction setting: 0 = +dir, 1 = -dir</p> <p>Measurement mode: 0 = C, 1 = +P, 2 = -P 3 = P-P, 4 = P-P/2</p> <p>Pass/fail judgment: 0 = C-OFF, 1 = C-3, 2 = r-3, 3 = r-4, 4 = r-5, 5 = r-6, 6 = r-7</p> <p>-LIMIT: -99.9999 to +99.9999</p> <p>+LIMIT: -99.9999 to +99.9999</p> <p>LIMIT3: -99.9999 to +99.9999</p> <p>LIMIT4: -99.9999 to +99.9999</p> <p>LIMIT5: -99.9999 to +99.9999</p> <p>LIMIT6: -99.9999 to +99.9999</p> <p>Rank 1 display color: 0 = Off, 1 = Red, 2 = Green, 3 = Orange</p> <p>Rank 2 display color: 0 = Off, 1 = Red, 2 = Green, 3 = Orange</p> <p>Rank 3 display color: 0 = Off, 1 = Red, 2 = Green, 3 = Orange</p> <p>Rank 4 display color: 0 = Off, 1 = Red, 2 = Green, 3 = Orange</p> <p>Rank 5 display color: 0 = Off, 1 = Red, 2 = Green, 3 = Orange</p> <p>Rank 6 display color: 0 = Off, 1 = Red, 2 = Green, 3 = Orange</p> <p>Rank 7 display color: 0 = Off, 1 = Red, 2 = Green, 3 = Orange</p> <p>Preset value: -99.9999 to +99.9999</p> </td> </tr> </table>	1	S	r	△	<CH>	△	<SET No.>	△	<Direction setting>	10	<Measurement mode>	△	<Pass/fail judgment>	△	<table border="1"> <tr> <td colspan="6">&lt;-LIMIT&gt;</td> <td>20</td> <td>△</td> <td colspan="3">&lt;+LIMIT&gt;</td> <td>30</td> <td>△</td> </tr> <tr> <td colspan="6">&lt;LIMIT3&gt;</td> <td>40</td> <td>△</td> <td colspan="3">&lt;LIMIT4&gt;</td> <td>50</td> <td>△</td> </tr> <tr> <td colspan="6">&lt;LIMIT5&gt;</td> <td>60</td> <td>△</td> <td colspan="3">&lt;LIMIT6&gt;</td> <td>70</td> <td>△</td> </tr> <tr> <td colspan="3">&lt;Rank 1 display color&gt;</td> <td>70</td> <td>△</td> <td colspan="3">&lt;Rank 2 display color&gt;</td> <td>△</td> <td colspan="3">&lt;Rank 3 display color&gt;</td> <td>△</td> <td colspan="3">&lt;Rank 4 display color&gt;</td> <td>△</td> </tr> <tr> <td colspan="3">&lt;Rank 5 display color&gt;</td> <td>80</td> <td>△</td> <td colspan="3">&lt;Rank 6 display color&gt;</td> <td>△</td> <td colspan="3">&lt;Rank 7 display color&gt;</td> <td>△</td> <td colspan="3"></td> </tr> <tr> <td colspan="11">&lt;Preset value&gt;</td> <td>90</td> <td>C<sub>R</sub></td> <td>L<sub>F</sub></td> <td>92</td> </tr> </table>													<-LIMIT>						20	△	<+LIMIT>			30	△	<LIMIT3>						40	△	<LIMIT4>			50	△	<LIMIT5>						60	△	<LIMIT6>			70	△	<Rank 1 display color>			70	△	<Rank 2 display color>			△	<Rank 3 display color>			△	<Rank 4 display color>			△	<Rank 5 display color>			80	△	<Rank 6 display color>			△	<Rank 7 display color>			△				<Preset value>											90	C <sub>R</sub>	L <sub>F</sub>	92	Data details	<p>CH: 01 (fixed)</p> <p>SET No.: 1 to 7</p> <p>Direction setting: 0 = +dir, 1 = -dir</p> <p>Measurement mode: 0 = C, 1 = +P, 2 = -P 3 = P-P, 4 = P-P/2</p> <p>Pass/fail judgment: 0 = C-OFF, 1 = C-3, 2 = r-3, 3 = r-4, 4 = r-5, 5 = r-6, 6 = r-7</p> <p>-LIMIT: -99.9999 to +99.9999</p> <p>+LIMIT: -99.9999 to +99.9999</p> <p>LIMIT3: -99.9999 to +99.9999</p> <p>LIMIT4: -99.9999 to +99.9999</p> <p>LIMIT5: -99.9999 to +99.9999</p> <p>LIMIT6: -99.9999 to +99.9999</p> <p>Rank 1 display color: 0 = Off, 1 = Red, 2 = Green, 3 = Orange</p> <p>Rank 2 display color: 0 = Off, 1 = Red, 2 = Green, 3 = Orange</p> <p>Rank 3 display color: 0 = Off, 1 = Red, 2 = Green, 3 = Orange</p> <p>Rank 4 display color: 0 = Off, 1 = Red, 2 = Green, 3 = Orange</p> <p>Rank 5 display color: 0 = Off, 1 = Red, 2 = Green, 3 = Orange</p> <p>Rank 6 display color: 0 = Off, 1 = Red, 2 = Green, 3 = Orange</p> <p>Rank 7 display color: 0 = Off, 1 = Red, 2 = Green, 3 = Orange</p> <p>Preset value: -99.9999 to +99.9999</p>
1	S	r	△	<CH>	△	<SET No.>	△	<Direction setting>	10	<Measurement mode>	△	<Pass/fail judgment>	△																																																																																																								
<table border="1"> <tr> <td colspan="6">&lt;-LIMIT&gt;</td> <td>20</td> <td>△</td> <td colspan="3">&lt;+LIMIT&gt;</td> <td>30</td> <td>△</td> </tr> <tr> <td colspan="6">&lt;LIMIT3&gt;</td> <td>40</td> <td>△</td> <td colspan="3">&lt;LIMIT4&gt;</td> <td>50</td> <td>△</td> </tr> <tr> <td colspan="6">&lt;LIMIT5&gt;</td> <td>60</td> <td>△</td> <td colspan="3">&lt;LIMIT6&gt;</td> <td>70</td> <td>△</td> </tr> <tr> <td colspan="3">&lt;Rank 1 display color&gt;</td> <td>70</td> <td>△</td> <td colspan="3">&lt;Rank 2 display color&gt;</td> <td>△</td> <td colspan="3">&lt;Rank 3 display color&gt;</td> <td>△</td> <td colspan="3">&lt;Rank 4 display color&gt;</td> <td>△</td> </tr> <tr> <td colspan="3">&lt;Rank 5 display color&gt;</td> <td>80</td> <td>△</td> <td colspan="3">&lt;Rank 6 display color&gt;</td> <td>△</td> <td colspan="3">&lt;Rank 7 display color&gt;</td> <td>△</td> <td colspan="3"></td> </tr> <tr> <td colspan="11">&lt;Preset value&gt;</td> <td>90</td> <td>C<sub>R</sub></td> <td>L<sub>F</sub></td> <td>92</td> </tr> </table>													<-LIMIT>						20	△	<+LIMIT>			30	△	<LIMIT3>						40	△	<LIMIT4>			50	△	<LIMIT5>						60	△	<LIMIT6>			70	△	<Rank 1 display color>			70	△	<Rank 2 display color>			△	<Rank 3 display color>			△	<Rank 4 display color>			△	<Rank 5 display color>			80	△	<Rank 6 display color>			△	<Rank 7 display color>			△				<Preset value>											90	C <sub>R</sub>	L <sub>F</sub>	92																		
<-LIMIT>						20	△	<+LIMIT>			30	△																																																																																																									
<LIMIT3>						40	△	<LIMIT4>			50	△																																																																																																									
<LIMIT5>						60	△	<LIMIT6>			70	△																																																																																																									
<Rank 1 display color>			70	△	<Rank 2 display color>			△	<Rank 3 display color>			△	<Rank 4 display color>			△																																																																																																					
<Rank 5 display color>			80	△	<Rank 6 display color>			△	<Rank 7 display color>			△																																																																																																									
<Preset value>											90	C <sub>R</sub>	L <sub>F</sub>	92																																																																																																							
Data details	<p>CH: 01 (fixed)</p> <p>SET No.: 1 to 7</p> <p>Direction setting: 0 = +dir, 1 = -dir</p> <p>Measurement mode: 0 = C, 1 = +P, 2 = -P 3 = P-P, 4 = P-P/2</p> <p>Pass/fail judgment: 0 = C-OFF, 1 = C-3, 2 = r-3, 3 = r-4, 4 = r-5, 5 = r-6, 6 = r-7</p> <p>-LIMIT: -99.9999 to +99.9999</p> <p>+LIMIT: -99.9999 to +99.9999</p> <p>LIMIT3: -99.9999 to +99.9999</p> <p>LIMIT4: -99.9999 to +99.9999</p> <p>LIMIT5: -99.9999 to +99.9999</p> <p>LIMIT6: -99.9999 to +99.9999</p> <p>Rank 1 display color: 0 = Off, 1 = Red, 2 = Green, 3 = Orange</p> <p>Rank 2 display color: 0 = Off, 1 = Red, 2 = Green, 3 = Orange</p> <p>Rank 3 display color: 0 = Off, 1 = Red, 2 = Green, 3 = Orange</p> <p>Rank 4 display color: 0 = Off, 1 = Red, 2 = Green, 3 = Orange</p> <p>Rank 5 display color: 0 = Off, 1 = Red, 2 = Green, 3 = Orange</p> <p>Rank 6 display color: 0 = Off, 1 = Red, 2 = Green, 3 = Orange</p> <p>Rank 7 display color: 0 = Off, 1 = Red, 2 = Green, 3 = Orange</p> <p>Preset value: -99.9999 to +99.9999</p>																																																																																																																				

Chapter 1  
Instructions for  
Safe Use

Chapter 2  
Product  
Overview

Chapter 3  
Connection and  
Installation

Chapter 4  
Names and  
Functions

Chapter 5  
Mode of Use

Chapter 6  
Parameter  
Settings

Chapter 7  
External Input and  
Output

Chapter 8  
Troubleshooting

Chapter 9  
Specifications

5) SET No. setting command (Ns)

Function	Sets the SET numbers.									
Transmission format (PC → display unit)	<table border="1" style="display: inline-table; border-collapse: collapse;"> <tr> <td style="text-align: center;">1</td> <td style="text-align: center;">N</td> <td style="text-align: center;">s</td> <td style="text-align: center;">△</td> <td style="text-align: center;">&lt;CH&gt;</td> <td style="text-align: center;">△</td> <td style="text-align: center;">&lt;SET No.&gt;</td> <td style="text-align: center;">C<sub>R</sub></td> <td style="text-align: center;">L<sub>F</sub></td> </tr> </table>	1	N	s	△	<CH>	△	<SET No.>	C <sub>R</sub>	L <sub>F</sub>
1	N	s	△	<CH>	△	<SET No.>	C <sub>R</sub>	L <sub>F</sub>		
Reply format (Display unit → PC)	<table border="1" style="display: inline-table; border-collapse: collapse;"> <tr> <td style="text-align: center;">1</td> <td style="text-align: center;">R</td> <td style="text-align: center;">s</td> <td style="text-align: center;">△</td> <td style="text-align: center;">&lt;Receipt acknowledgment code&gt;</td> <td style="text-align: center;">C<sub>R</sub></td> <td style="text-align: center;">L<sub>F</sub></td> </tr> </table>	1	R	s	△	<Receipt acknowledgment code>	C <sub>R</sub>	L <sub>F</sub>		
1	R	s	△	<Receipt acknowledgment code>	C <sub>R</sub>	L <sub>F</sub>				
Data details	CH: 01 (fixed) SET No.: 1 to 7									

Chapter 1  
Instructions for  
Safe Use

6) SET No. request command (Nr)

Function	Requests the SET numbers.									
Transmission format (PC → display unit)	<table border="1" style="display: inline-table; border-collapse: collapse;"> <tr> <td style="text-align: center;">1</td> <td style="text-align: center;">N</td> <td style="text-align: center;">r</td> <td style="text-align: center;">△</td> <td style="text-align: center;">&lt;CH&gt;</td> <td style="text-align: center;">C<sub>R</sub></td> <td style="text-align: center;">L<sub>F</sub></td> </tr> </table>	1	N	r	△	<CH>	C <sub>R</sub>	L <sub>F</sub>		
1	N	r	△	<CH>	C <sub>R</sub>	L <sub>F</sub>				
Reply format (Display unit → PC)	<table border="1" style="display: inline-table; border-collapse: collapse;"> <tr> <td style="text-align: center;">1</td> <td style="text-align: center;">N</td> <td style="text-align: center;">r</td> <td style="text-align: center;">△</td> <td style="text-align: center;">&lt;CH&gt;</td> <td style="text-align: center;">△</td> <td style="text-align: center;">&lt;SET No.&gt;</td> <td style="text-align: center;">C<sub>R</sub></td> <td style="text-align: center;">L<sub>F</sub></td> </tr> </table>	1	N	r	△	<CH>	△	<SET No.>	C <sub>R</sub>	L <sub>F</sub>
1	N	r	△	<CH>	△	<SET No.>	C <sub>R</sub>	L <sub>F</sub>		
Data details	CH: 01 (fixed) SET No.: 1 to 7									

Chapter 2  
Product  
Overview

Chapter 3  
Connection and  
Installation

Chapter 4  
Names and  
Functions

7) Zero reset command (Zr)

Function	Resets the current value to 0 (or to the preset value, if one has been set).							
Transmission format (PC → display unit)	<table border="1" style="display: inline-table; border-collapse: collapse;"> <tr> <td style="text-align: center;">1</td> <td style="text-align: center;">Z</td> <td style="text-align: center;">r</td> <td style="text-align: center;">△</td> <td style="text-align: center;">&lt;CH&gt;</td> <td style="text-align: center;">C<sub>R</sub></td> <td style="text-align: center;">L<sub>F</sub></td> </tr> </table>	1	Z	r	△	<CH>	C <sub>R</sub>	L <sub>F</sub>
1	Z	r	△	<CH>	C <sub>R</sub>	L <sub>F</sub>		
Reply format (Display unit → PC)	<table border="1" style="display: inline-table; border-collapse: collapse;"> <tr> <td style="text-align: center;">1</td> <td style="text-align: center;">R</td> <td style="text-align: center;">s</td> <td style="text-align: center;">△</td> <td style="text-align: center;">&lt;Receipt acknowledgment code&gt;</td> <td style="text-align: center;">C<sub>R</sub></td> <td style="text-align: center;">L<sub>F</sub></td> </tr> </table>	1	R	s	△	<Receipt acknowledgment code>	C <sub>R</sub>	L <sub>F</sub>
1	R	s	△	<Receipt acknowledgment code>	C <sub>R</sub>	L <sub>F</sub>		
Data details	CH: 01 (fixed)							

Chapter 5  
Mode of Use

Chapter 6  
Parameter  
Settings

8) Peak clear command (Pr)

Function	Clears the peak value (+P, -P) to the current value.							
Transmission format (PC → display unit)	<table border="1" style="display: inline-table; border-collapse: collapse;"> <tr> <td style="text-align: center;">1</td> <td style="text-align: center;">P</td> <td style="text-align: center;">r</td> <td style="text-align: center;">△</td> <td style="text-align: center;">&lt;CH&gt;</td> <td style="text-align: center;">C<sub>R</sub></td> <td style="text-align: center;">L<sub>F</sub></td> </tr> </table>	1	P	r	△	<CH>	C <sub>R</sub>	L <sub>F</sub>
1	P	r	△	<CH>	C <sub>R</sub>	L <sub>F</sub>		
Reply format (Display unit → PC)	<table border="1" style="display: inline-table; border-collapse: collapse;"> <tr> <td style="text-align: center;">1</td> <td style="text-align: center;">R</td> <td style="text-align: center;">s</td> <td style="text-align: center;">△</td> <td style="text-align: center;">&lt;Receipt acknowledgment code&gt;</td> <td style="text-align: center;">C<sub>R</sub></td> <td style="text-align: center;">L<sub>F</sub></td> </tr> </table>	1	R	s	△	<Receipt acknowledgment code>	C <sub>R</sub>	L <sub>F</sub>
1	R	s	△	<Receipt acknowledgment code>	C <sub>R</sub>	L <sub>F</sub>		
Data details	CH: 01 (fixed)							

Chapter 7  
External Input and  
Output

Chapter 8  
Troubleshooting

Chapter 9  
Specifications

Chapter 1  
Instructions for  
Safe Use

Chapter 2  
Product  
Overview

Chapter 3  
Connection and  
Installation

Chapter 4  
Names and  
Functions

Chapter 5  
Mode of Use

Chapter 6  
Parameter  
Settings

Chapter 7  
External Input and  
Output

Chapter 8  
Troubleshooting

Chapter 9  
Specifications

9) Data hold command (Hr)

Function	Controls the hold state of the current measurement value.										
Transmission format (PC → display unit)	<table border="1"> <tr> <td>1</td> <td>H</td> <td>r</td> <td>Δ</td> <td>&lt;CH&gt;</td> <td>Δ</td> <td>&lt;Control code&gt;</td> <td>C<sub>R</sub></td> <td>L<sub>F</sub></td> <td>9</td> </tr> </table>	1	H	r	Δ	<CH>	Δ	<Control code>	C <sub>R</sub>	L <sub>F</sub>	9
1	H	r	Δ	<CH>	Δ	<Control code>	C <sub>R</sub>	L <sub>F</sub>	9		
Reply format (Display unit → PC)	<table border="1"> <tr> <td>1</td> <td>R</td> <td>s</td> <td>Δ</td> <td>&lt;Receipt acknowledgment code&gt;</td> <td>C<sub>R</sub></td> <td>L<sub>F</sub></td> <td>6</td> </tr> </table>	1	R	s	Δ	<Receipt acknowledgment code>	C <sub>R</sub>	L <sub>F</sub>	6		
1	R	s	Δ	<Receipt acknowledgment code>	C <sub>R</sub>	L <sub>F</sub>	6				
Data details	CH: 01 (fixed) Control code: 0 = OFF, 1 = ON										

10) Error reset command (Er)

Function	Resets an error.								
Transmission format (PC → display unit)	<table border="1"> <tr> <td>1</td> <td>E</td> <td>r</td> <td>Δ</td> <td>&lt;CH&gt;</td> <td>C<sub>R</sub></td> <td>L<sub>F</sub></td> <td>7</td> </tr> </table>	1	E	r	Δ	<CH>	C <sub>R</sub>	L <sub>F</sub>	7
1	E	r	Δ	<CH>	C <sub>R</sub>	L <sub>F</sub>	7		
Reply format (Display unit → PC)	<table border="1"> <tr> <td>1</td> <td>R</td> <td>s</td> <td>Δ</td> <td>&lt;Receipt acknowledgment code&gt;</td> <td>C<sub>R</sub></td> <td>L<sub>F</sub></td> <td>6</td> </tr> </table>	1	R	s	Δ	<Receipt acknowledgment code>	C <sub>R</sub>	L <sub>F</sub>	6
1	R	s	Δ	<Receipt acknowledgment code>	C <sub>R</sub>	L <sub>F</sub>	6		
Data details	CH: 01 (fixed)								



11) Unit status request command (Cr)

Function	Requests the status.																								
Transmission format (PC → display unit)	<table border="1" style="display: inline-table; border-collapse: collapse;"> <tr> <td style="text-align: center;">1</td> <td style="text-align: center;">7</td> </tr> <tr> <td style="text-align: center;">C</td> <td style="text-align: center;">r</td> </tr> <tr> <td style="text-align: center;">Δ</td> <td style="text-align: center;">Δ</td> </tr> <tr> <td style="text-align: center;">&lt;CH&gt;</td> <td style="text-align: center;">&lt;CH&gt;</td> </tr> <tr> <td style="text-align: center;">C<sub>R</sub></td> <td style="text-align: center;">L<sub>F</sub></td> </tr> </table>	1	7	C	r	Δ	Δ	<CH>	<CH>	C <sub>R</sub>	L <sub>F</sub>														
1	7																								
C	r																								
Δ	Δ																								
<CH>	<CH>																								
C <sub>R</sub>	L <sub>F</sub>																								
Reply format (Display unit → PC)	<table border="1" style="display: inline-table; border-collapse: collapse;"> <tr> <td style="text-align: center;">1</td> <td style="text-align: center;">10</td> <td style="text-align: center;">19</td> </tr> <tr> <td style="text-align: center;">C</td> <td style="text-align: center;">r</td> <td style="text-align: center;">L<sub>F</sub></td> </tr> <tr> <td style="text-align: center;">Δ</td> <td style="text-align: center;">Δ</td> <td style="text-align: center;">Δ</td> </tr> <tr> <td style="text-align: center;">&lt;CH&gt;</td> <td style="text-align: center;">&lt;Status 1&gt;</td> <td style="text-align: center;">&lt;Status 2&gt;</td> </tr> <tr> <td style="text-align: center;">Δ</td> <td style="text-align: center;">Δ</td> <td style="text-align: center;">Δ</td> </tr> <tr> <td style="text-align: center;">&lt;Error 1&gt;</td> <td style="text-align: center;">&lt;Error 2&gt;</td> <td style="text-align: center;">&lt;Error 3&gt;</td> </tr> <tr> <td style="text-align: center;">Δ</td> <td style="text-align: center;">Δ</td> <td style="text-align: center;">Δ</td> </tr> <tr> <td style="text-align: center;">&lt;Error 4&gt;</td> <td style="text-align: center;">C<sub>R</sub></td> <td style="text-align: center;">L<sub>F</sub></td> </tr> </table>	1	10	19	C	r	L <sub>F</sub>	Δ	Δ	Δ	<CH>	<Status 1>	<Status 2>	Δ	Δ	Δ	<Error 1>	<Error 2>	<Error 3>	Δ	Δ	Δ	<Error 4>	C <sub>R</sub>	L <sub>F</sub>
1	10	19																							
C	r	L <sub>F</sub>																							
Δ	Δ	Δ																							
<CH>	<Status 1>	<Status 2>																							
Δ	Δ	Δ																							
<Error 1>	<Error 2>	<Error 3>																							
Δ	Δ	Δ																							
<Error 4>	C <sub>R</sub>	L <sub>F</sub>																							
Data details	<p>CH: 01 (fixed)</p> <p>Status code 1</p> <p>D7: fixed to 0</p> <p>D6: fixed to 0</p> <p>D5: fixed to 1</p> <p>D4: fixed to 1</p> <p>D3: * Not defined</p> <p>D2: Parameter editing (0 = not executed, 1 = executing)</p> <p>D1: ABS display (0 = reset, 1 = ABS)</p> <p>D1: * Not defined</p> <p>Status code 2</p> <p>D7: fixed to 0</p> <p>D6: fixed to 0</p> <p>D5: fixed to 1</p> <p>D4: fixed to 1</p> <p>D3: * Not defined</p> <p>D2: * Not defined</p> <p>D1: Hold state (0 = OFF, 1 = ON)</p> <p>D0: SET No. external specification (1 = Specified externally)</p> <p>Error code 1</p> <p>D7: fixed to 0</p> <p>D6: fixed to 0</p> <p>D5: fixed to 1</p> <p>D4: fixed to 1</p> <p>D3: [Err110] Detector type error</p> <p>D2: [Err200] Parameter R/W error</p> <p>D1: * Not defined</p> <p>D0: * Not defined</p> <p>Error code 2</p> <p>D7: fixed to 0</p> <p>D6: fixed to 0</p> <p>D5: fixed to 1</p> <p>D4: fixed to 1</p> <p>D3: [Err100] Detector not connected</p> <p>D2: [Err130] Detector communication error</p> <p>D1: * Not defined</p> <p>D0: [Err***] Detector coordinate value error</p>																								

Chapter 1  
Instructions for  
Safe Use

Chapter 2  
Product  
Overview

Chapter 3  
Connection and  
Installation

Chapter 4  
Names and  
Functions

Chapter 5  
Mode of Use

Chapter 6  
Parameter  
Settings

Chapter 7  
External Input and  
Output

Chapter 8  
Troubleshooting

Chapter 9  
Specifications

Chapter 1  
Instructions for  
Safe Use

Chapter 2  
Product  
Overview

Chapter 3  
Connection and  
Installation

Chapter 4  
Names and  
Functions

Chapter 5  
Mode of Use

Chapter 6  
Parameter  
Settings

Chapter 7  
External Input and  
Output

Chapter 8  
Troubleshooting

Chapter 9  
Specifications

	<p>Error code 3</p> <p>D7: fixed to 0</p> <p>D6: fixed to 0</p> <p>D5: fixed to 1</p> <p>D4: fixed to 1</p> <p>D3: [Err210] Internal memory overflow</p> <p>D2: [Err120] Detector overstroke</p> <p>D1: [Err300] Communication error</p> <p>D0: [Err301] Communication command error</p> <p>Error code 4</p> <p>D7: fixed to 0</p> <p>D6: fixed to 0</p> <p>D5: fixed to 1</p> <p>D4: fixed to 1</p> <p>D3: [Err310] Limit value setting error</p> <p>D2: [Err320] Position overflow</p> <p>D1: [Err311] Parameter setting error</p> <p>D0: [INIT] Parameter initialization</p>
--	---

12) Measurement data 1 request command (D1)

Function	Requests measurement data.																									
Transmission format (PC → display unit)	<table border="1"> <tr> <td>1</td> <td>D</td> <td>1</td> <td>Δ</td> <td>&lt;CH&gt;</td> <td>Δ</td> <td>&lt;SET No.&gt;</td> <td>C<sub>R</sub></td> <td>9</td> <td>L<sub>F</sub></td> </tr> </table>	1	D	1	Δ	<CH>	Δ	<SET No.>	C <sub>R</sub>	9	L <sub>F</sub>															
1	D	1	Δ	<CH>	Δ	<SET No.>	C <sub>R</sub>	9	L <sub>F</sub>																	
Reply format (Display unit → PC)	<table border="1"> <tr> <td>1</td> <td>D</td> <td>1</td> <td>Δ</td> <td>&lt;CH&gt;</td> <td>Δ</td> <td>&lt;SET No.&gt;</td> <td>Δ</td> <td>&lt;Measurement mode&gt;</td> <td>10</td> </tr> <tr> <td colspan="7">&lt;Measurement value&gt;</td> <td>Δ</td> <td>20</td> <td>&lt;Pass/fail judgment&gt;</td> <td>Δ</td> <td>&lt;Display mode&gt;</td> <td>C<sub>R</sub></td> <td>24</td> <td>L<sub>F</sub></td> </tr> </table>	1	D	1	Δ	<CH>	Δ	<SET No.>	Δ	<Measurement mode>	10	<Measurement value>							Δ	20	<Pass/fail judgment>	Δ	<Display mode>	C <sub>R</sub>	24	L <sub>F</sub>
1	D	1	Δ	<CH>	Δ	<SET No.>	Δ	<Measurement mode>	10																	
<Measurement value>							Δ	20	<Pass/fail judgment>	Δ	<Display mode>	C <sub>R</sub>	24	L <sub>F</sub>												
Data details	<p>CH: 01 (fixed)</p> <p>SET No.: 0, 1–7 (0 for the SET No. currently displayed)</p> <p>Measurement mode: 0 = C, 1 = +P, 2 = –P 3 = P–P, 4 = P–P/2</p> <p>Measurement value: –99.9999 to +99.9999</p> <p>Pass/fail judgment code: When C-3: 1 = –NG, 2 = OK, 3 = +NG When R-3 to 7: 1 to 7 (Gives a reply of “0” when the pass/fail judgment is set to OFF)</p> <p>On occurrence of an error (Err) 9</p> <p>Display mode: 0 = 0.1 μm, 1 = 1 μm, 2 = 10 μm</p>																									

## 7-4-4 Transmission without Using a Communication Command

The initial parameter P06 can be set to enable data output without use of communication commands from an external device.

This function is useful for output to a printer or the like.

The internal timer or the EXT RS IN signal line is used as a data output trigger.

### ■ Internal timer mode (Initial parameter P06 = Sd-2)

Data is automatically output according to the internal timer. Data output starts when the power is turned ON.

Specify the internal timer value by setting initial parameter P07.

Output format (Display unit → External)	<table border="1"><tr><td>1</td><td> </td><td> </td><td> </td><td> </td><td> </td><td> </td><td> </td><td>10</td></tr><tr><td colspan="8">&lt;Measurement value&gt;</td><td>C</td><td>L</td></tr><tr><td colspan="8"></td><td>R</td><td>F</td></tr></table>	1								10	<Measurement value>								C	L									R	F
1								10																						
<Measurement value>								C	L																					
								R	F																					
Data details	Measurement value: -99.9999 to +99.9999																													

### ⓘ Output using EXT RS IN

Output using the EXT RS IN signal line can be used when initial parameter P06 is set to Sd-1. Note that a command must not be issued concurrently with a communication command. This could cause a communication error.

The output format is the same as that for internal timer mode, as described above.

Chapter 1  
Instructions for  
Safe Use

Chapter 2  
Product  
Overview

Chapter 3  
Connection and  
Installation

Chapter 4  
Names and  
Functions

Chapter 5  
Mode of Use

Chapter 6  
Parameter  
Settings

Chapter 7  
External Input and  
Output

Chapter 8  
Troubleshooting

Chapter 9  
Specifications

# 8. Troubleshooting

## 8-1 Errors

If an error occurs during use, an error No. is displayed as shown in the table below, and the backlight turns red.

No.	Description	Cause	How to clear
Init (Display)	Parameter initialization	Parameters have been initialized by manipulating initial parameter P98.	Use the [RESET] key or a communication command to make the unit execute an error reset.

No.	Details
000's numbers	Errors detected by the detector itself. In most cases these are critical errors due to deterioration or to mechanical or electrical damage. In some cases they may also be temporary errors due to noise. To check, you are recommended to replace the unit with a normal one and find out if the error also occurs with the normal unit.
100's numbers	Detector-related errors detected by the display unit. In most cases these are temporary errors such as connection mistakes.
200's numbers	Errors relating to internal control in the display unit. Errors due to deterioration or to mechanical or electrical damage.
300's numbers	Errors relating to display unit operation, etc. Note that communication-related errors can sometimes be temporary errors due to noise. To check, you are recommended to replace the unit with a normal one and find out if the error also occurs with the normal unit.

No.	Description	Cause	How to clear
020	System parameter fault	A fault has occurred in the detector's system parameters.	The detector must be repaired or replaced.
021	Correction parameter fault	A fault has occurred in the detector's correction parameters.	(Same as above)
022	Operation history data fault	A fault has occurred in the detector's operation history data.	(Same as above)
030	Parameter initialization	The detector's parameters have been initialized.	(Same as above)
040	Low light level	The light level of the light source in the detector has dropped.	Use the [RESET] key or a communication command to make the unit execute an error reset. If the fault is not cleared, the detector must be repaired or replaced.
050	Sensor IC communication data error	A data error has occurred in the detector during communication with the sensor IC.	(Same as above)
060	ABS data fault	ABS data could not be read correctly in the detector.	(Same as above)

No.	Description	Cause	How to clear
100	Detector not connected	No detector is connected or the detector has a failure, such as a broken wire	This is automatically cleared when a normal detector is detected.
110	Detector type error	An unusable detector has been connected and started.	Connect a usable detector.
120	Overstroke	The maximum stroke has been exceeded, due to an upthrust, for example.	Use the [RESET] key or a communication command to make the unit execute an error reset.
130	Detector communication error	There is an error in communication with the detector, or the detector has a failure such as a broken wire.	(Same as above)

Chapter 1  
Instructions for  
Safe Use

Chapter 2  
Product  
Overview

Chapter 3  
Connection and  
Installation

Chapter 4  
Names and  
Functions

Chapter 5  
Mode of Use

No.	Description	Cause	How to clear
200	Parameter R/W error	A fault has occurred during reading or writing of parameters.	Press the [RESET] key for at least 5 seconds or use a communication command to make the unit execute an error reset.
210	Internal memory overflow	The internal memory has overflowed.	Use the [RESET] key or a communication command to make the unit execute an error reset.

Chapter 6  
Parameter  
Settings

Chapter 7  
External Input and  
Output

Chapter 8  
Troubleshooting

Chapter 9  
Specifications

No.	Description	Cause	How to clear
300	External communication error	One of the following RS-232C communication errors has occurred: parity error, framing error, overrun error, 1-second communication stoppage, 10-second communication interruption due to RTS OFF, or other reason.	Use the [RESET] key or a communication command to make the unit execute an error reset, or transmit a normal command.
301	External command error	Communication command format malfunction Data exceeds the specified range when parameter writing is activated by a communication command.	(Same as above)
310	Limit value setting	Abnormal relation between upper and lower limit values of a SET No. parameter	[RESET] key Input again * If you do not input revised values, measurement will be possible but you will not be able to obtain correct judgment results.
311	Parameter setting error	Data exceeds the specified range when setting parameters by using the keys.	[RESET] key Input again
320	Position overflow	The measurement value has exceeded the indication range	Adjust the measurement value to within the indication range.

## 8-2 In Case of Trouble

Chapter 1  
Instructions for  
Safe Use

Chapter 2  
Product  
Overview

Chapter 3  
Connection and  
Installation

Chapter 4  
Names and  
Functions

Chapter 5  
Mode of Use

Chapter 6  
Parameter  
Settings

Chapter 7  
External Input and  
Output

Chapter 8  
Troubleshooting

Chapter 9  
Specifications

Trouble	Check
Power does not turn ON.	Is the power supply connected properly? Is power being supplied properly? Has the connection been made with the polarity (+/-) reversed? Is the appropriate power voltage used? Is there sufficient current capacity?
The measured value remains unchanged.	Is a hold signal being input? When a hold signal is being input, "HOLD" is displayed in the upper right corner of the display. Turn the power OFF, then disconnect and re-connect the detector.
Inaccurate	Is the detector installed securely with no play? Is the measurement terminal loose? Is the detector being subjected to any excessive vibration or impact? For example, when a detector is put on a guide rail and moved up and down by an air cylinder, the impact from a strong collision with the mechanical stopper on the upper edge (back clearance side) may cause erroneous counting. Install a shock absorber or other means of softening the impact, reduce the air cylinder operation speed, or take other appropriate measures. Is the spindle moving up and down properly? If the spindle is tightened excessively during installation, it may affect spindle operation.
Keys do not respond to input.	Are the keys locked? To unlock the keys, simultaneously hold down the [SET], [P-CLEAR] and [RESET] keys for about 3 seconds. Turn the power OFF, wait a few seconds, and then turn the power back ON.

# 9. Specifications

## 9-1 Main Specifications

No.	Item	Details		
		SA-CD1N	SA-CD1N/BO	SA-CD1N/RS
1	Product model	SA-CD1N	SA-CD1N/BO	SA-CD1N/RS
2	Power voltage	12 to 24 VDC ±10%		
3	Consumption current	200 mA or less (when connected to detectors)		
4	Indicator	Polarity, 6 digits, mode display, LCD with green/red backlight		
5	Display resolution	0.1 μm/1 μm/10 μm		
6	Display range	-99.9999 to 99.9999 mm		
7	Quantization error	±1 digit		
8	Sensor head input number	1 ch		
9	Sensor head supply voltage	5 VDC ±10%		
10	Reset function	Can be reset from any position (by key, external signal, and RS commands)		
11	Preset function	Polarity and 6 digits		
12	Data hold	Indications and data held by external signals		
13	Peak hold	+P, -P, P-P, P-P/2 (set using key and RS commands)		
14	Measurement direction switch	+/- (switchable setting)		
15	Error function	Equipped		
16	Pass / fail judgment	-NG/OK/NG		
17	Measurement conditions registration	7 types (key and RS commands)		
18	BCD	None	Equipped	None
19	RS-232C	None	None	Equipped
20	Input signal	Reset/hold/peak clear		
21	Output signal	-NG/OK/+NG/Error		
22	Operating ambient temperature	0 to 50°C (provided there is no condensation or freezing) When storing: -10 to +60°C		
23	Operating ambient humidity	35 to 85% RH, When storing: 35 to 85% RH		
24	Resistance to vibration	10 to 150 Hz, double amplitude of 0.75 mm, or acceleration of 48 m/s <sup>2</sup> (switching frequency: 58 Hz) Two hours each in the X, Y, and Z directions		
25	Materials	Outer surface: polyester/Case: ABS		
26	Weight	Approximately 60 g	Approximately 110 g	Approximately 110 g

Chapter 1  
Instructions for  
Safe Use

Chapter 2  
Product  
Overview

Chapter 3  
Connection and  
Installation

Chapter 4  
Names and  
Functions

Chapter 5  
Mode of Use

Chapter 6  
Parameter  
Settings

Chapter 7  
External Input and  
Output

Chapter 8  
Troubleshooting

Chapter 9  
Specifications

## 9-2 Outline Dimensional Drawings

Chapter 1  
Instructions for  
Safe Use

Chapter 2  
Product  
Overview

Chapter 3  
Connection and  
Installation

Chapter 4  
Names and  
Functions

Chapter 5  
Mode of Use

Chapter 6  
Parameter  
Settings

Chapter 7  
External Input and  
Output

Chapter 8  
Troubleshooting

Chapter 9  
Specifications

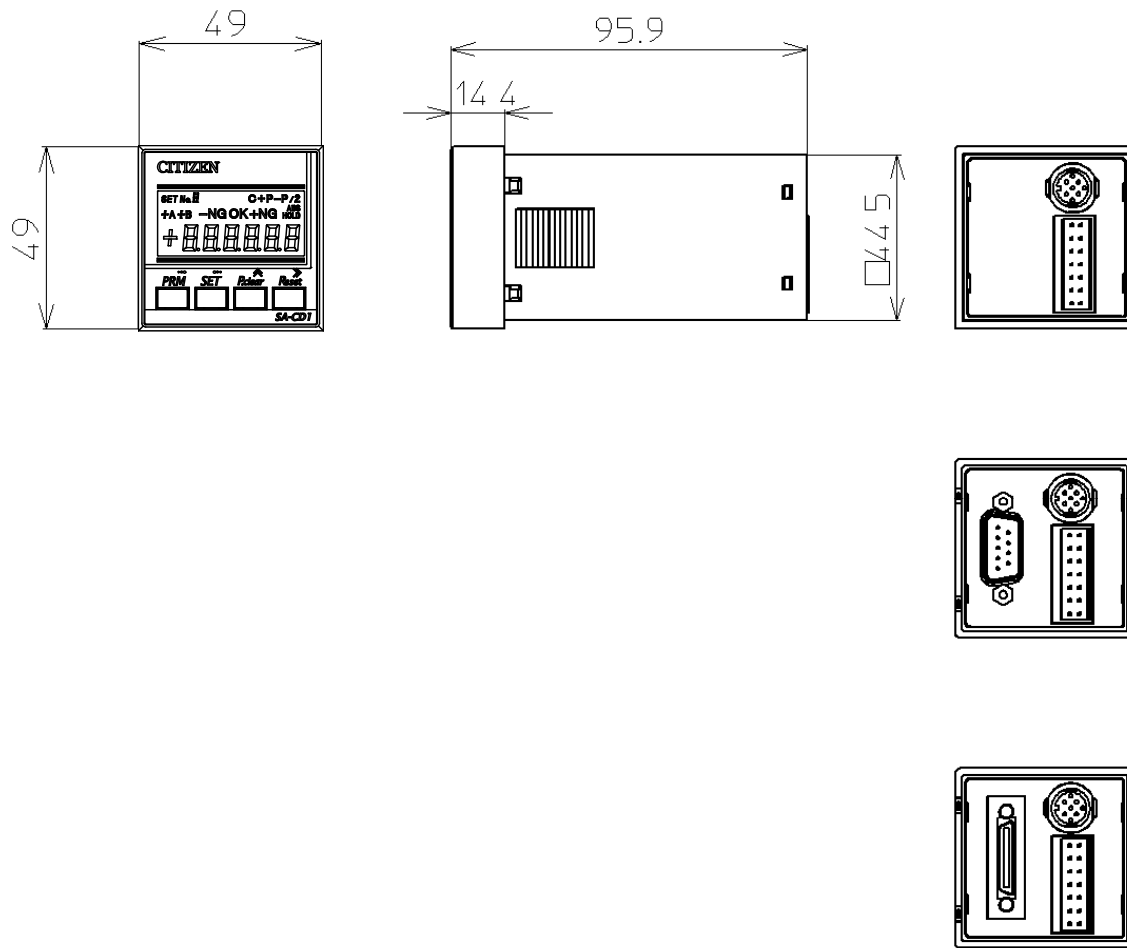





# CITIZEN

**CITIZEN FINEDEVICE CO., LTD.**

6663-2, Funatsu, Fujikawaguchiko-machi, Yamanashi Pref., 401-0395, Japan

TEL: 0555-22-1141 FAX: 0555-23-2106

U4M0058(1)

左ページ