

Combustion Pressure Sensors (For Measurement)

Part Name CAS-15S

Applications R&D support, measurement – M5 type

【Outline Drawings】

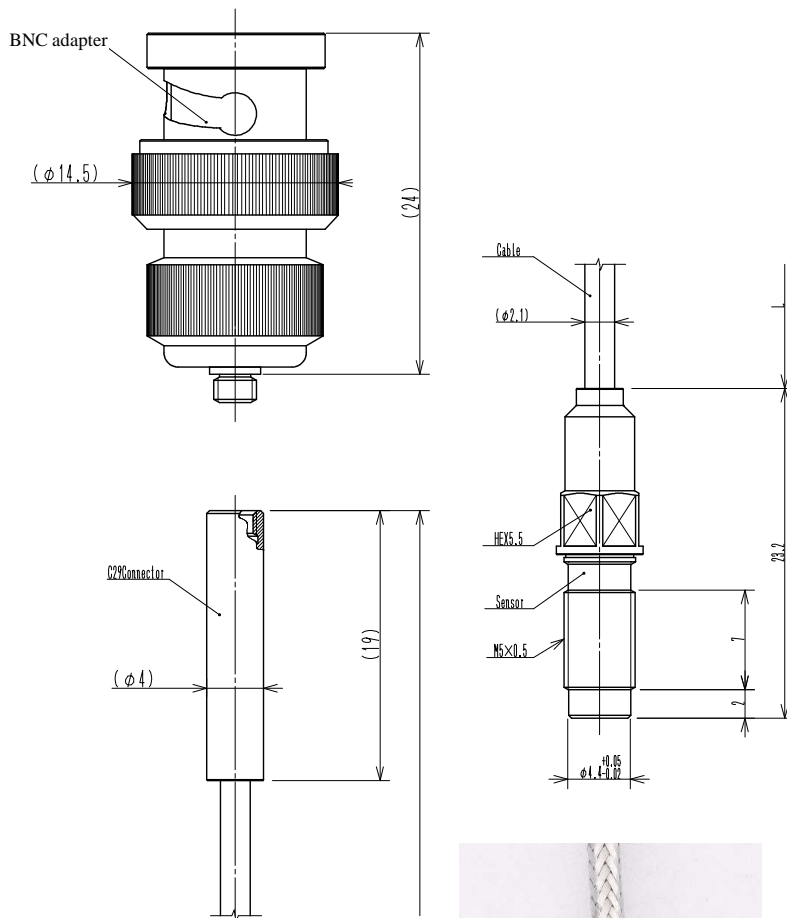

【Mounting Drawing (Example)】

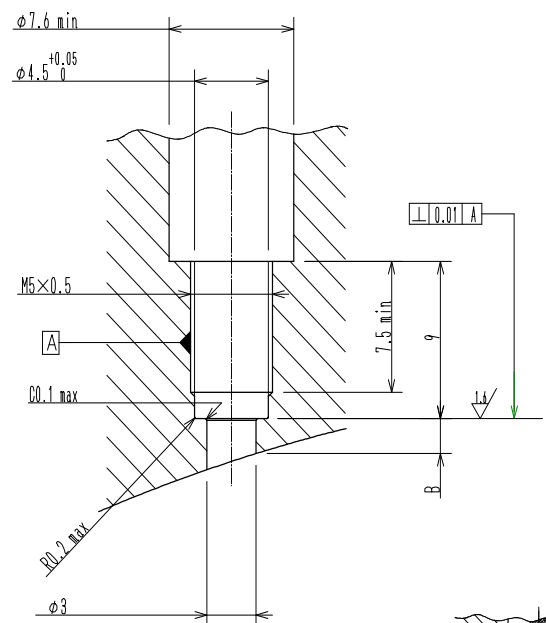

B (mm)	Material
≥ 2	Steel
≥ 4	Cast iron, Aluminum Alloy

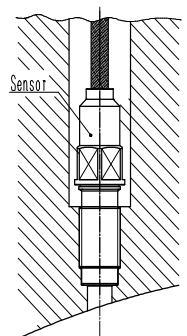

CAS-15S mounting example

Item	Details
Part No.	CAS-15S
Detectable pressure range	0~25 MPa (0~250bar)
Sensitivity	≐ -220pC/MPa (-22pC/bar)
Linearity ※1)	≦ ±0.5%FSO
Response frequency range	> 140kHz
Insulation resistance	≧ 10 ¹³ Ω(25°C)
Measuring temperature range at pressure-sensitive face	~350°C
Form of fastening (screw, hex)	M5×0.5mm、HEX5.5
Cooling	Non-Cooled
Cable, output terminal	Dedicated low-noise cable, BNC connector
Tightening torque	1.5N·m(Fastening to an aluminum block)

※1) Linearity (%FSO) is the maximum error allowable in the model specifications under standard operating conditions.

$$\pm \text{Linearity}(\%) = \frac{\text{Max}\Delta A}{A} \times 100$$

A=Value at the maximum pressure application indicated on the reference line

... The reference line is the line of sensor output values approximated using the least squares method at a given pressure.

ΔA=The difference between the value on the output curve and the value on the reference line (output value - approximate value)

MaxΔA=The value on the output curve at the greatest divergence from the reference line, the maximum value of ΔA

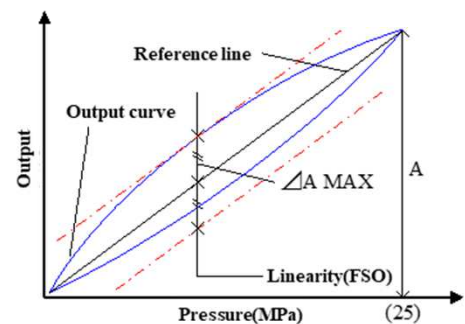

※2) The above applies to the sensing section only.

An adapter can be fitted for mounting.

Charge amplifiers adjusted for the output are available separately.

Please contact us for further information.

【Note】 This product is subject to change without notice.

Inquiries
Sales Section, CPS Department, Kitamimaki Plant
Tel: 0268-67-1808 Fax:0268-67-1804
URL;http://cfd.citizen.co.jp